



823 N. Hammonds Ferry Rd.

Suite B.

Linthicum Heights MD 21090

1.800.544.1188

Model Number- DM-HC390CG53

Frame Style- Aluminum Cart

Engine Type- Honda GX390, pull start

Pump Type- Comet RW5535

Drive Type- Gear Reduction

Unloader - External Unloader

Average Operational Spec's- 5.0 GPM @ 3,000 PSI @ 3500 RPM's

Designated Orifice Size - 6.0



DIRT MONKEE

WARNINGS:

DO NOT OPERATE YOUR PRESSURE WASHER UNTIL YOU HAVE READ AND UNDERSTAND YOUR MANUAL INCLUDING ALL OF THE OPERATING INSTRUCTIONS, SAFETY RULES AND PRECAUTIONS.

HIGH PRESSURE WATER SPRAY CAN CAUSE SERIOUS INJURY OR DEATH

Never aim spray tools at self or anyone else. Never put any body part in front of the spray nozzle.

WEAR PERSONAL PROTECTIVE EQUIPMENT

Always wear eye protection or face shield to protect against airborne debris from flying into face or eyes. Hearing protection is recommended, especially for use with gas engine driven equipment.

Long pants and shoes or boots should be worn. Additional protective equipment is recommended when using chemicals or cleaning detergents as well as other corrosives or abrasives.

Keep bystanders, children, and pets a safe distance away from cleaning area.

Do NOT spray water at delicate surfaces. When cleaning fragile objects, pull trigger away from object and then direct the spray carefully at the surface. Start further away and move closer as appropriate.

USE CAUTION after turning off a pressure washer and preparing to disconnect equipment. There may still be high-pressure fluid present in the cleaning system. Pressure should be released by squeezing gunjet trigger after motor has completely stopped.

When using chemicals, know exactly what you are using and read precautions and instructions carefully. Keeping a copy of Safety Data Sheet available is recommended.

GASOLINE ENGINE & ELECTRIC MOTOR PRECAUTIONS

Engine operation manual supplied with pressure washer should be followed including all precautions, operating procedures and maintenance. This manual can also be acquired from the Engine manufacturer or local small engine service center.

- FUELING - NEVER FILL ENGINE WITH GASOLINE WHILE THE ENGINE IS RUNNING, HOT, OR NEAR AN OPEN FLAME.

- NEVER run pressure washers in enclosed spaces. Engine Exhaust contains carbon monoxide, a poisonous gas. Breathing engine exhaust fumes can lead to serious illness or death.

- BEWARE - Engine and Pump surfaces can become VERY HOT. Touching the muffler, crankcase, hot exhaust and other surfaces can result in serious burns.

- NEVER spray flammable liquids or other fluids other than water with the pressure washer. DO NOT operate the pressure washer in the presence of flammable or explosive materials including gases, vapors, or dust particles.

- When transporting the pressure washer, ALWAYS close the fuel shut off valve to prevent fuel from leaking from the engine.

RECEIPT, INITIAL SETUP, AND OPERATION OF YOUR NEW PRESSURE WASHER

INSPECT for FREIGHT DAMAGE

Upon arrival of your new pressure washer, be sure to inspect it for concealed freight damage. Any damage should be reported to the delivery agent right away. Contact the selling dealer with any questions or concerns related to the freight/delivery.

OIL LEVELS

Check the oil levels of the pump, gearbox, or engine if applicable. Most equipment are shipped with oil from the factory and the oil housings are sealed. If applicable, you may have to remove the shipping plug and install the vented oil cap or dipstick prior to use. Oil type is defined on the parts breakdown and engine manual.

Routinely check the pump oil level and condition prior to use of the pressure washer. Pump oil should be changed after the first 50 hours of use (break-in period). After that, the oils should be changed an average of every 3 months or 200 hours of operation. Milky or cloudy is an indication of the presence of water, can be the result of water seal or plunger failure, and should be changed immediately.

WATER SUPPLY

Pressure washer pumps must be supplied with water flow that exceeds the Maximum Flow Rate (GPM = gallons per minute) for which the pump is rated. Most manufacturers recommend this flow rate to be 1.5x greater than the maximum flow rating. This means that a 4 gpm pump should be fed around 6 gpm. Some water supplies are affected by other sources of demand for water; like irrigation systems, washing machines, showers & toilets, etc. It might be necessary to prohibit those other sources of water consumption while the pressure washer is running.

Starving the pump for adequate water supply, feeding the pump aerated water, or a water flow with excessive fluid turbulence will cause cavitation. Cavitation will increase pump wear and tear, eventually causing damage and possible pump failure.

On most pumps, the maximum rated inlet water temperature should NOT exceed 140° Fahrenheit. The warmer the temperature of the water supply the greater the chance of cavitation.

WATER QUALITY

The water supplied to the pressure washer must be free of debris or particulate matter. Portable models intended to be connected to a garden hose are typically equipped with an inlet water strainer. Skid mounted and tank-fed pressure washers should be installed with an appropriate inlet water strainer.

The inlet water strainer should be inspected daily for debris and cleaned as often as necessary to prevent water restriction and prevent debris from contaminating the pump.

WATER SUPPLY/GARDEN HOSE

For portable (non-tank fed machines) a heavy duty, non-collapsible garden hose with an inner diameter of 3/4" is recommended. The recommended hose length is a minimum of 10' and a maximum of 50'. A single section of hose should be used to prevent leaking connections, and the connections should be screwed together without garden hose quick disconnects. Garden hose quick disconnects, especially those with check valves, can promote cavitation and pressure loss. Prior to connecting the hose to the pressure washer, it should be flushed with water to prevent strainer contamination and clogged nozzles.

Once the hose is connected to the pump, squeezing the gunjet and purging air from the system is encouraged. At this point inspect for and correct any leaks present prior to starting the pressure washer.

EXTENDED BYPASS AND UNLOADER OPERATION

All pressure washers are equipped with some form of Unloader Valve. The unloader valve bypasses water when the gunjet is closed and water is prohibited from exiting the system. It can also facilitate the manipulation of the output pressure by decreasing the flow of water being forced through the nozzle. The pressure and unloader valve are set during the manufacturing and testing process. No adjustments to the machine should be necessary for initial operation.

Pressure washer pumps are cooled by the water that passes through them. When in bypass, the water cycles through the bypass and back into the pump preventing the cooling process. During operation the machine should not be left running without the gunjet open (spraying) for more than a few minutes because it can accelerate wear and tear of the service parts and lead to pump failure. If the operator will not be spraying water for more than a few minutes the machine should be shut off.

SPRAY NOZZLE TYPES AND SELECTION

NOZZLE PURPOSE

Spray nozzles are a critical variable in achieving the desired performance from your pressure washer. Pressure Washer Pumps do not produce pressure, only constant flow. Applying a certain amount of restriction to the flow results in the byproduct of pressure. Without the proper nozzle orifice size, proper pressure and flow might not be reached.

NOZZLE IDENTIFICATION

Spray nozzles are identified by their **orifice size** and **spray pattern**. The nozzle ID number indicates the orifice size and spray pattern and is usually a four or five digit number. The first two digits of the nozzle ID indicate the spray pattern; 0°, 15°, 25°, and 40° are the most common patterns. Those patterns are also indicated by the color of the plastic on flat tip QC nozzles. Color designations are:

RED - 0° YELLOW – 15° GREEN – 25° WHITE - 40°

The last two to three digits of the nozzle ID indicate the orifice size, an industry standard value based on an equation. It does not necessarily indicate the size of the opening or the flow rate. EXAMPLE of NOZZLE ID:

15045 = 15° Pattern, 4.5 Orifice

4003 = 40° Pattern, 3.0 Orifice

STANDARD SPRAY NOZZLE USES AND APPLICATIONS

- 0° (RED) – Least used. Hard surface cleaning, like gum off concrete, grease/mud off metal surfaces, etc. Long distance rinsing. Calibrating the Unloader Valve.
- 15° (Yellow) – Narrow Chisel tip. Removing paint/graffiti from metal, wood, or masonry surfaces. Commercial kitchen cleaning. Removing barnacles. Removing heavy mold or mildew stains.
- 25° (Green) – Medium fan tip. General Cleaning. Cleaning porches, sidewalks, driveways. Rinsing vinyl siding, patio furniture, etc.
- 40° (White) – Widest fan tip. Washing delicate surfaces. Rinsing boats or automobiles. Cleaning wood or fabric awnings.

SHUT DOWN & STORAGE

SHUT DOWN

1. For temporary breaks during the workday, the pressure washer can be shut down by turning the Engine Cut Off switch to the OFF position. At the end of the workday, the engine should be shut down by closing the fuel valve and allowing the engine to run until it stalls out and stops.
2. Release the pressure in the high pressure hose by squeezing the trigger on the gunjet.
3. Shut off the water supply and disconnect the hoses, both garden and high pressure. Quick disconnects last longer if they are separated when not in use. High pressure hoses also last longer if they are drained of fluid when not in use.
4. Drain water from remaining tools including the gunjet lance assembly.
5. If the machine is going to be stored and not used for an extended period, RV/Boat Antifreeze should be fed into the pump. This protects it from freeze as well as lubricating the seals and valves.
6. Fuel that will sit for 30-90 days should be stabilized with a fuel product. If storing for over 90 days, it is best to drain the fuel tank in addition to running the carburetor out of fuel.

Recommended Service Schedule

The outlined schedule is a guideline for preventative maintenance. It is intended to achieve optimal performance for the life of your machine.

Item		Each use	First month or 20 hours	Every 3 months or 50 hours	Every 6 months or 100 hours	Every year or 300 hours
Engine Oil	Check Level	x				
	Change		x		x	
Air Cleaner	Check	x				
	Clean			x		
	Replace				x	
Fuel Tank Sediment Cup	Clean				x	
Spark Plug	Check				x	
	Replace					x
Idle Speed	Adjust					x
Valve Clearance	Adjust					x
Fuel Tank & Filter	Clean				x	
Fuel Tube	Replace					x
Pump Oil	Check Level	x				
	Change		x		x	
Check Valves	Clean & Inspect				x	
Water Seals	Check for signs of wear				x	
Unloader	Check for signs of wear				x	
	Adjust				x	
Gear Oil	Check Level	x				
	Change		x			x

INTRODUCTION

Thank you for purchasing a Honda engine. We want to help you to get the best results from your new engine and to operate it safely. This manual contains information on how to do that; please read it carefully before operating the engine. If a problem should arise, or if you have any questions about your engine, consult an authorized Honda servicing dealer.

All information in this publication is based on the latest product information available at the time of printing. Honda Motor Co., Ltd. reserves the right to make changes at any time without notice and without incurring any obligation. No part of this publication may be reproduced without written permission.

This manual should be considered a permanent part of the engine and should remain with the engine if resold.

Review the instructions provided with the equipment powered by this engine for any additional information regarding engine startup, shutdown, operation, adjustments or any special maintenance instructions.

United States, Puerto Rico, and U.S. Virgin Islands:
We suggest you read the warranty policy to fully understand its coverage and your responsibilities of ownership. The warranty policy is a separate document that should have been given to you by your dealer.

SAFETY MESSAGES

Your safety and the safety of others are very important. We have provided important safety messages in this manual and on the engine. Please read these messages carefully.

A safety message alerts you to potential hazards that could hurt you or others. Each safety message is preceded by a safety alert symbol  and one of three words, DANGER, WARNING, or CAUTION.

These signal words mean:

 **DANGER**

You **WILL** be **KILLED** or **SERIOUSLY HURT** if you don't follow instructions.

 **WARNING**

You **CAN** be **KILLED** or **SERIOUSLY HURT** if you don't follow instructions.

 **CAUTION**

You **CAN** be **HURT** if you don't follow instructions.

Each message tells you what the hazard is, what can happen, and what you can do to avoid or reduce injury.

DAMAGE PREVENTION MESSAGES

You will also see other important messages that are preceded by the word **NOTICE**.

This word means:

NOTICE

Your engine or other property can be damaged if you don't follow instructions.

The purpose of these messages is to help prevent damage to your engine, other property, or the environment.

© 2007 Honda Motor Co., Ltd. — All Rights Reserved

37Z5F602
00X37-Z5F-6020

GX240U1-GX270U-GX340U1-GX390U1

HONDA

OWNER'S MANUAL

MANUEL DE L'UTILISATEUR

MANUAL DEL PROPIETARIO

GX240 · GX270 · GX340 · GX390

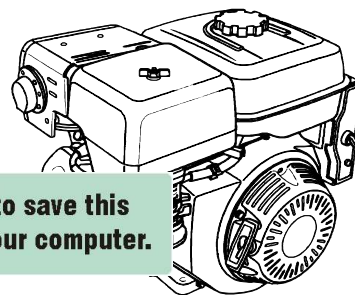

Click here to save this manual to your computer.



WARNING:



The engine exhaust from this product contains chemicals known to the State of California to cause cancer, birth defects or other reproductive harm.

CONTENTS

INTRODUCTION	1	SEDIMENT CUP	12
SAFETY MESSAGES	1	SPARK PLUG	12
SAFETY INFORMATION	2	SPARK ARRESTER	13
SAFETY LABEL LOCATION	2	IDLE SPEED	13
COMPONENT & CONTROL LOCATION	2	HELPFUL TIPS & SUGGESTIONS	13
FEATURES	3	STORING YOUR ENGINE	13
BEFORE OPERATION CHECKS	3	TRANSPORTING	14
OPERATION	4	TAKING CARE OF UNEXPECTED PROBLEMS	15
SAFE OPERATING PRECAUTIONS	4	FUSE REPLACEMENT	15
STARTING THE ENGINE	4	TECHNICAL & CONSUMER INFORMATION	16
STOPPING THE ENGINE	5	Serial Number Location	16
SETTING ENGINE SPEED	6	Battery Connections for Electric Starter	16
SERVICING YOUR ENGINE	7	Remote Control Linkage	16
THE IMPORTANCE OF MAINTENANCE	7	Carburetor Modifications for High Altitude Operation	16
MAINTENANCE SAFETY	7	Emission Control System Information	17
SAFETY PRECAUTIONS	7	Air Index	18
MAINTENANCE SCHEDULE	7	Specifications	18
REFUELING	8	Tuneup Specifications	19
ENGINE OIL	8	Quick Reference Information	19
Recommended Oil	8	Wiring Diagrams	19
Oil Level Check	9	CONSUMER INFORMATION	20
Oil Change	9	Distributor/Dealer Locator Information	20
REDUCTION CASE OIL	9	Customer Service Information	20
Recommended Oil	9		
Oil Level Check	9		
Oil Change	10		
AIR CLEANER	10		
Inspection	10		
Cleaning	10		

ENGLISH

FRANÇAIS

ESPAÑOL

SAFETY INFORMATION

- Understand the operation of all controls and learn how to stop the engine quickly in case of emergency. Make sure the operator receives adequate instruction before operating the equipment.
- Do not allow children to operate the engine. Keep children and pets away from the area of operation.
- Your engine's exhaust contains poisonous carbon monoxide. Do not run the engine without adequate ventilation, and never run the engine indoors.
- The engine and exhaust become very hot during operation. Keep the engine at least 1 meter (3 feet) away from buildings and other equipment during operation. Keep flammable materials away, and do not place anything on the engine while it is running.

SAFETY LABEL LOCATION

This label warns you of potential hazards that can cause serious injury. Read it carefully. If the label comes off or becomes hard to read, contact your Honda dealer for replacement.



For Canadian types only: French label comes with the engine.

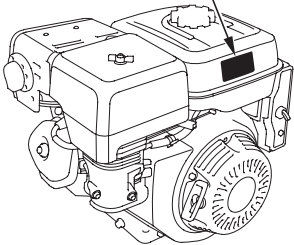

Gasoline is highly flammable and explosive. Turn engine off and let cool before refueling.



The engine emits toxic poisonous carbon monoxide gas. Do not run in an enclosed area.



Read Owner's Manual before operation.

COMPONENT & CONTROL LOCATION

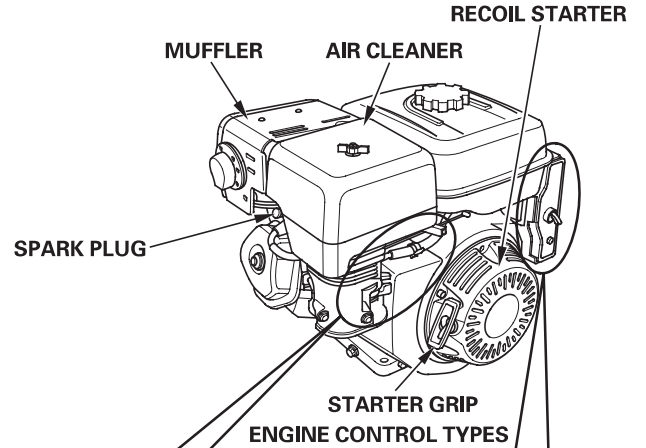
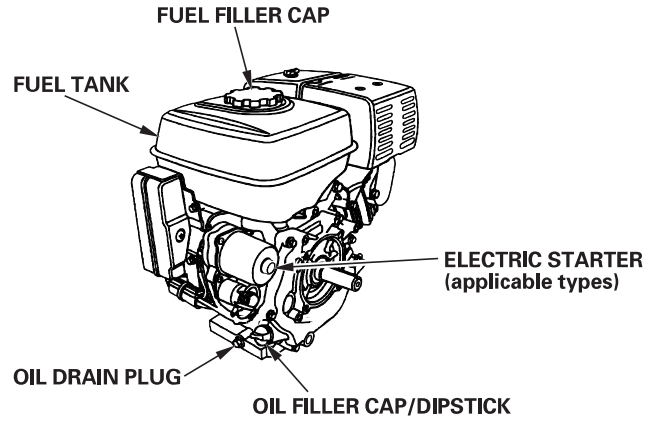

CHOKE LEVER

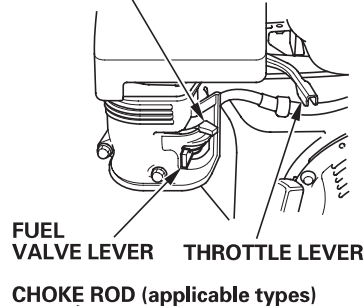

EXCEPT ELECTRIC STARTER TYPES

ENGINE SWITCH

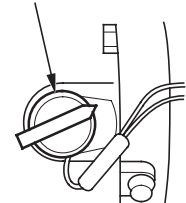

ENGINE SWITCH

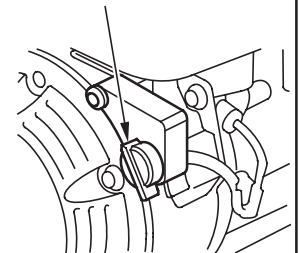

ELECTRIC STARTER TYPES

ENGINE SWITCH

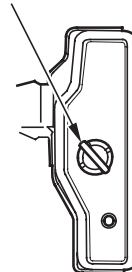

FEATURES

OIL ALERT® SYSTEM (applicable types)

“Oil Alert is a registered trademark in the United States”

The Oil Alert system is designed to prevent engine damage caused by an insufficient amount of oil in the crankcase. Before the oil level in the crankcase can fall below a safe limit, the Oil Alert system will automatically stop the engine (the engine switch will remain in the ON position).

If the engine stops and will not restart, check the engine oil level (see page 9) before troubleshooting in other areas.

CIRCUIT PROTECTOR (applicable types)

The circuit protector protects the battery charging circuit. A short circuit, or a battery connected with reverse polarity, will trip the circuit breaker.

The green indicator inside the circuit protector will pop out to show that the circuit protector has switched off. If this occurs, determine the cause of the problem, and correct it before resetting the circuit protector.

Push the circuit protector button to reset.

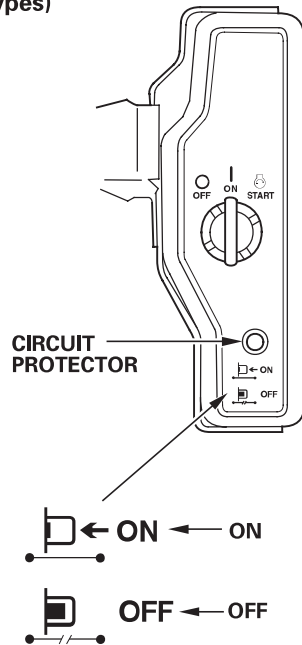

BEFORE OPERATION CHECKS

IS YOUR ENGINE READY TO GO?

For your safety, and to maximize the service life of your equipment, it is very important to take a few moments before you operate the engine to check its condition. Be sure to take care of any problem you find, or have your servicing dealer correct it, before you operate the engine.

⚠ WARNING

Improperly maintaining this engine, or failure to correct a problem before operation, can cause a malfunction in which you can be seriously hurt or killed.

Always perform a pre-operation inspection before each operation, and correct any problem.

Before beginning your pre-operation checks, be sure the engine is level and the engine switch is in the OFF position.

Always check the following items before you start the engine:

Check the General Condition of the Engine

1. Look around and underneath the engine for signs of oil or gasoline leaks.
2. Remove any excessive dirt or debris, especially around the muffler and recoil starter.
3. Look for signs of damage.
4. Check that all shields and covers are in place, and all nuts, bolts, and screws are tightened.

Check the Engine

1. Check the fuel level (see page 8). Starting with a full tank will help to eliminate or reduce operating interruptions for refueling.
2. Check the engine oil level (see page 9). Running the engine with a low oil level can cause engine damage.

The Oil Alert system (applicable types) will automatically stop the engine before the oil level falls below safe limits. However, to avoid the inconvenience of an unexpected shutdown, always check the engine oil level before startup.

3. Check the reduction case oil level on applicable types (see page 9). Oil is essential to reduction case operation and long life.
4. Check the air filter element (see page 10). A dirty air filter element will restrict air flow to the carburetor, reducing engine performance.
5. Check the equipment powered by this engine.

Review the instructions provided with the equipment powered by this engine for any precautions and procedures that should be followed before engine startup.

OPERATION

SAFE OPERATING PRECAUTIONS

Before operating the engine for the first time, please review the *SAFETY INFORMATION* section on page 2 and the *BEFORE OPERATION CHECKS* on page 3.

⚠ WARNING

Carbon monoxide gas is toxic. Breathing it can cause unconsciousness and even kill you.

Avoid any areas or actions that expose you to carbon monoxide.

Review the instructions provided with the equipment powered by this engine for any safety precautions that should be observed with engine startup, shutdown or operation.

STARTING THE ENGINE

1. Move the fuel valve lever to the ON position.

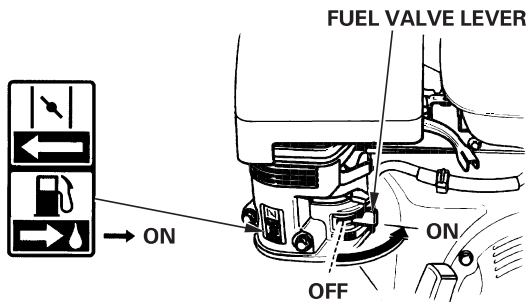

2. To start a cold engine, move the choke lever or choke rod (applicable types) to the CLOSED position.

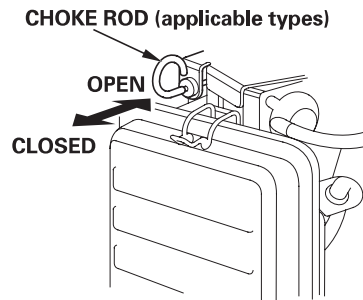
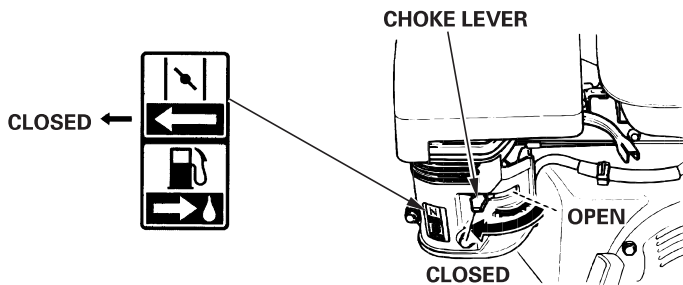

To restart a warm engine, leave the choke lever or choke rod in the OPEN position.

Some engine applications use a remote-mounted choke control rather than the engine-mounted choke lever shown here. Refer to the instructions provided by the equipment manufacturer.

3. Move the throttle lever away from the MIN. position, about 1/3 of the way toward the MAX. position.

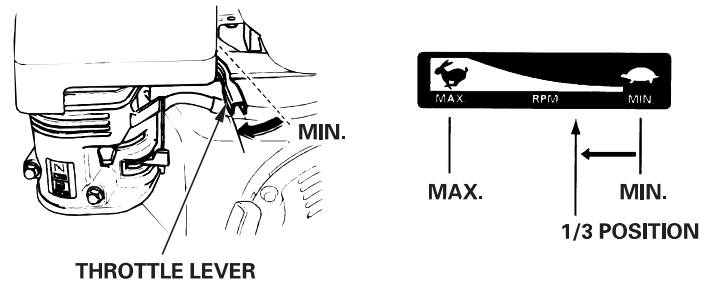

Some engine applications use a remote-mounted throttle control rather than the engine-mounted throttle lever shown here. Refer to the instructions provided by the equipment manufacturer.

4. Turn the engine switch to the ON position.

EXCEPT ELECTRIC STARTER TYPES

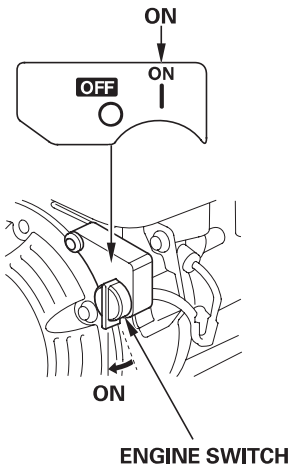
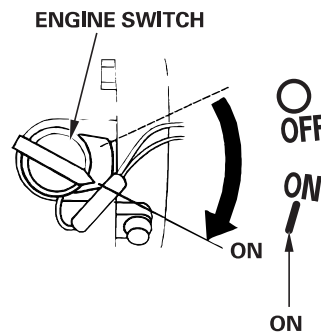

ELECTRIC STARTER TYPES

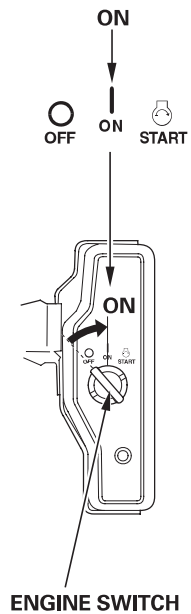

5. Operate the starter.

RECOIL STARTER

Pull the starter grip lightly until you feel resistance, then pull briskly in the direction of the arrow as shown below. Return the starter grip gently.

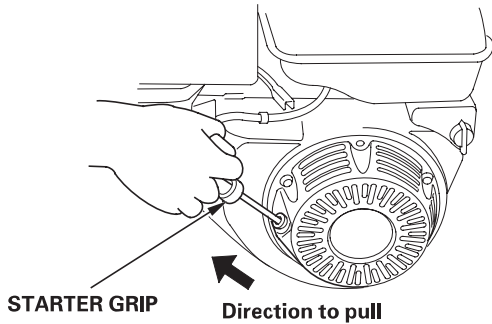

NOTICE

Do not allow the starter grip to snap back against the engine. Return it gently to prevent damage to the starter.

ELECTRIC STARTER (applicable types):

Turn the key to the START position, and hold it there until the engine starts.

If the engine fails to start within 5 seconds, release the key, and wait at least 10 seconds before operating the starter again.

NOTICE

Using the electric starter for more than 5 seconds at a time will overheat the starter motor and can damage it.

When the engine starts, release the key, allowing it to return to the ON position.

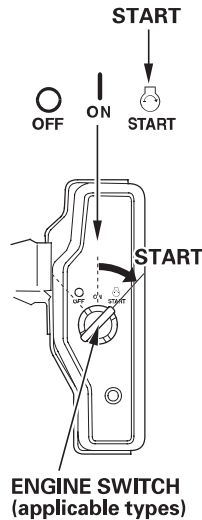

6. If the choke lever or choke rod (applicable types) has been moved to the CLOSED position to start the engine, gradually move it to the OPEN position as the engine warms up.

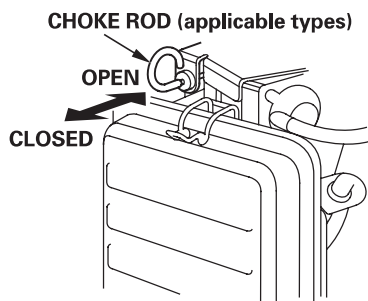
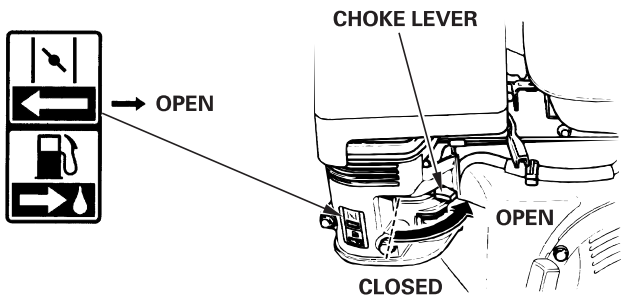

STOPPING THE ENGINE

To stop the engine in an emergency, simply turn the engine switch to the OFF position. Under normal conditions, use the following procedure. Refer to the instructions provided by the equipment manufacturer.

1. Move the throttle lever to the MIN. position.

Some engine applications use a remote-mounted throttle control rather than the engine-mounted throttle lever shown here.

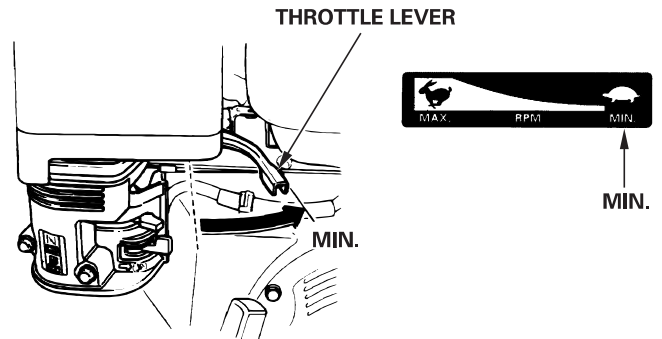

2. Turn the engine switch to the OFF position.

EXCEPT ELECTRIC STARTER TYPES

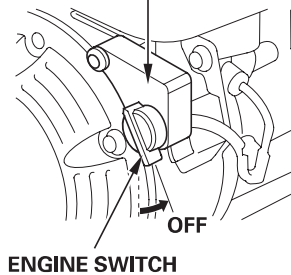
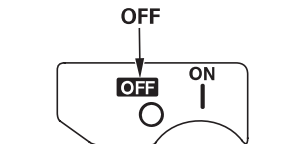
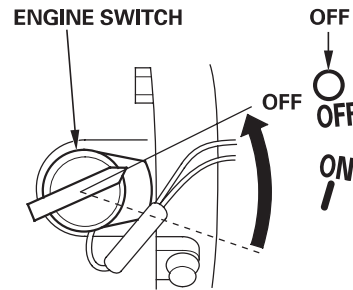

ELECTRIC STARTER TYPES

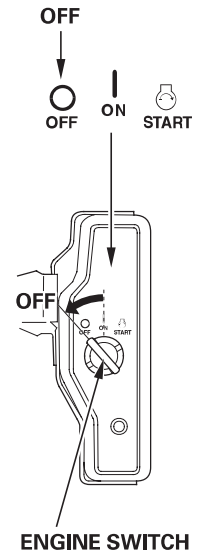

3. Turn the fuel valve lever to the OFF position.

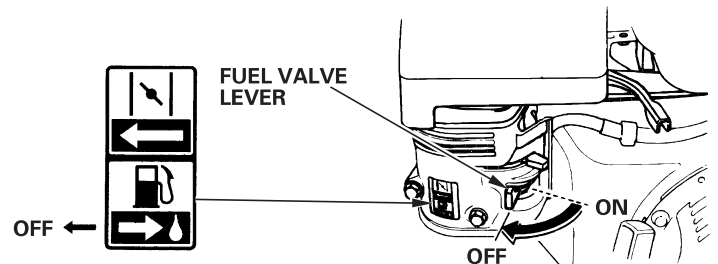

SETTING ENGINE SPEED

Position the throttle lever for the desired engine speed.

Some engine applications use a remote-mounted throttle control rather than the engine-mounted throttle lever shown here. Refer to the instructions provided by the equipment manufacturer.

For engine speed recommendations, refer to the instructions provided with the equipment powered by this engine.

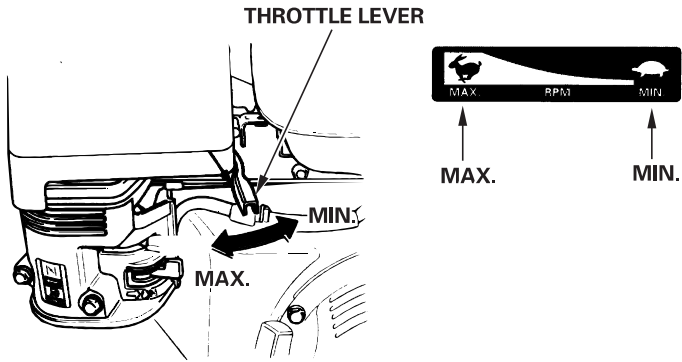

SERVICING YOUR ENGINE

THE IMPORTANCE OF MAINTENANCE

Good maintenance is essential for safe, economical and trouble-free operation. It will also help reduce pollution.

⚠ WARNING

Improper maintenance, or failure to correct a problem before operation, can cause a malfunction in which you can be seriously hurt or killed.

Always follow the inspection and maintenance recommendations and schedules in this owner's manual.

To help you properly care for your engine, the following pages include a maintenance schedule, routine inspection procedures, and simple maintenance procedures using basic hand tools. Other service tasks that are more difficult, or require special tools, are best handled by professionals and are normally performed by a Honda technician or other qualified mechanic.

The maintenance schedule applies to normal operating conditions. If you operate your engine under severe conditions, such as sustained high-load or high-temperature operation, or use in unusually wet or dusty conditions, consult your servicing dealer for recommendations applicable to your individual needs and use.

Maintenance, replacement, or repair of the emission control devices and systems may be performed by any engine repair establishment or individual, using parts that are "certified" to EPA standards.

MAINTENANCE SAFETY

Some of the most important safety precautions follow. However, we cannot warn you of every conceivable hazard that can arise in performing maintenance. Only you can decide whether or not you should perform a given task.

⚠ WARNING

Failure to properly follow maintenance instructions and precautions can cause you to be seriously hurt or killed.

Always follow the procedures and precautions in this owner's manual.

SAFETY PRECAUTIONS

- Make sure the engine is off before you begin any maintenance or repairs. This will eliminate several potential hazards:
 - **Carbon monoxide poisoning from engine exhaust.** Be sure there is adequate ventilation whenever you operate the engine.
 - **Burns from hot parts.** Let the engine and exhaust system cool before touching.
 - **Injury from moving parts.** Do not run the engine unless instructed to do so.
- Read the instructions before you begin, and make sure you have the tools and skills required.
- To reduce the possibility of fire or explosion, be careful when working around gasoline. Use only a nonflammable solvent, not gasoline, to clean parts. Keep cigarettes, sparks and flames away from all fuel related parts.

Remember that an authorized Honda servicing dealer knows your engine best and is fully equipped to maintain and repair it. To ensure the best quality and reliability, use only new genuine Honda parts or their equivalents for repair and replacement.

MAINTENANCE SCHEDULE

REGULAR SERVICE PERIOD (3) Perform at every indicated month or operating hour interval, whichever comes first.	Each Use	First Month or 20 Hrs	Every 3 Months or 50 Hrs	Every 6 Months or 100 Hrs	Every Year or 300 Hrs	Refer to Page
ITEM						
Engine oil	Check level	○				9
	Change		○	○		9
Reduction case oil (applicable types)	Check level	○				9
	Change		○	○		10
Air filter	Check	○				10
	Clean		○ (1)	○ *(1)		10 – 11
	Replace				○ **	
Sediment cup	Clean			○		12
Spark plug	Check-adjust			○		12
	Replace				○	
Spark arrester (applicable types)	Clean			○		13
Idle speed	Check-adjust				○ (2)	13
Valve clearance	Check-adjust				○ (2)	Shop manual
Combustion chamber	Clean	After every 500 Hrs. (2)				Shop manual
Fuel tank & filter	Clean			○ (2)		Shop manual
Fuel tube	Check	Every 2 years (Replace if necessary) (2)				Shop manual

- * • Internal vent carburetor with dual element type only.
- Cyclone type every 6 months or 150 hours.

INTERNAL VENT CARBURETOR TYPE

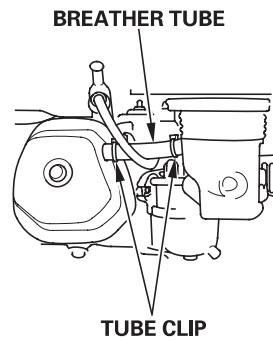

STANDARD TYPE

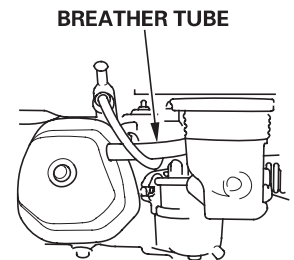

- ** • Replace paper element type only.
- Cyclone type every 2 years or 600 hours.

- (1) Service more frequently when used in dusty areas.
- (2) These items should be serviced by your servicing dealer, unless you have the proper tools and are mechanically proficient. Refer to Honda shop manual for service procedures.
- (3) For commercial use, log hours of operation to determine proper maintenance intervals.

Failure to follow this maintenance schedule could result in non-warrantable failures.

REFUELING

Recommended Fuel

Unleaded gasoline	
U.S.	Pump octane rating 86 or higher
Except U.S.	Research octane rating 91 or higher
	Pump octane rating 86 or higher

This engine is certified to operate on unleaded gasoline with a pump octane rating of 86 or higher (a research octane rating of 91 or higher).

Refuel in a well-ventilated area with the engine stopped. If the engine has been running, allow it to cool first. Never refuel the engine inside a building where gasoline fumes may reach flames or sparks.

You may use regular unleaded gasoline containing no more than 10% Ethanol (E10) or 5% Methanol by volume. In addition, Methanol must contain cosolvents and corrosion inhibitors. Use of fuels with content of Ethanol or Methanol greater than shown above may cause starting and/or performance problems. It may also damage metal, rubber, and plastic parts of the fuel system. Engine damage or performance problems that result from using a fuel with percentages of Ethanol or Methanol greater than shown above are not covered under warranty.

⚠ WARNING

Gasoline is highly flammable and explosive, and you can be burned or seriously injured when refueling.

- Stop engine and keep heat, sparks, and flame away.
- Refuel only outdoors.
- Wipe up spills immediately.

NOTICE

Fuel can damage paint and some types of plastic. Be careful not to spill fuel when filling your fuel tank. Damage caused by spilled fuel is not covered under the Distributor's Limited Warranty.

1. With the engine stopped and on a level surface, remove the fuel filler cap and check the fuel level. Refill the tank if the fuel level is low.
2. Add fuel to the bottom of the fuel level limit of the fuel tank. Do not overfill. Wipe up spilled fuel before starting the engine.

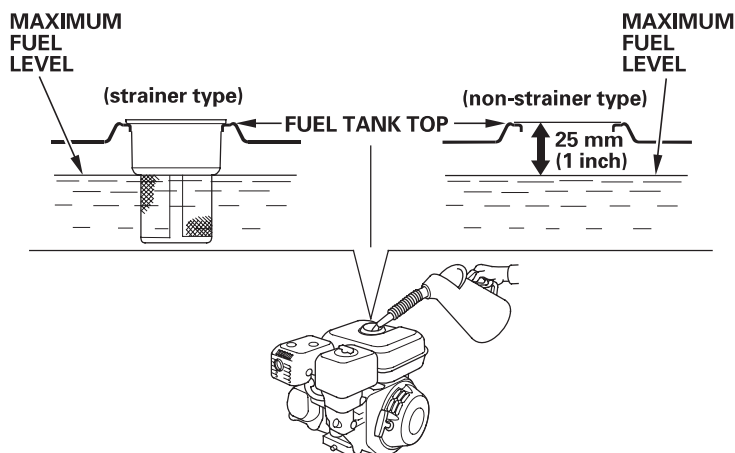

3. Refuel carefully to avoid spilling fuel. Do not fill the fuel tank completely. Fill tank to approximately 25 mm (1 inch) below the top of the fuel tank to allow for fuel expansion. It may be necessary to lower the fuel level depending on operating conditions. After refueling, tighten the fuel filler cap securely.

Keep gasoline away from appliance pilot lights, barbecues, electric appliances, power tools, etc.

Spilled fuel is not only a fire hazard, it causes environmental damage. Wipe up spills immediately.

ENGINE OIL

Oil is a major factor affecting performance and service life. Use 4-stroke automotive detergent oil.

Recommended Oil

Use 4-stroke motor oil that meets or exceeds the requirements for API service classification SJ or later (or equivalent). Always check the API service label on the oil container to be sure it includes the letters SJ or later (or equivalent).

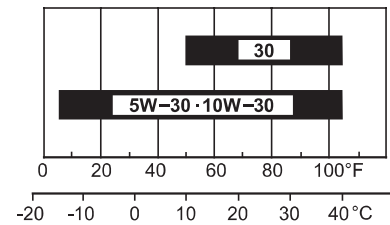

AMBIENT TEMPERATURE

SAE 10W-30 is recommended for general use. Other viscosities shown in the chart may be used when the average temperature in your area is within the indicated range.

Oil Level Check

Check the engine oil level with the engine stopped and in a level position.

1. Remove the oil filler cap/dipstick and wipe it clean.
2. Insert the oil filler cap/dipstick into the oil filler neck as shown, but do not screw it in, then remove it to check the oil level.
3. If the oil level is near or below the lower limit mark on the dipstick, fill with the recommended oil (see page 8) to the upper limit mark (bottom edge of the oil fill hole). Do not overfill.
4. Reinstall the oil filler cap/dipstick.

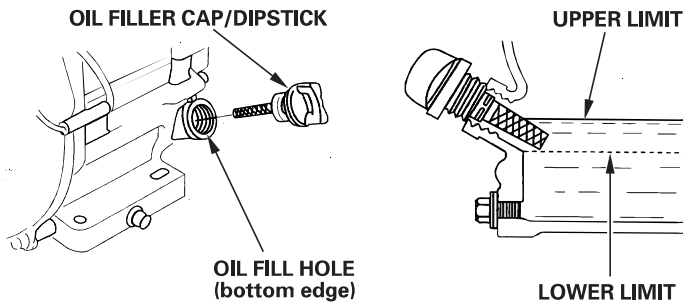

NOTICE

Running the engine with a low oil level can cause engine damage. This type of damage is not covered by the Distributor's Limited Warranty.

The Oil Alert system (applicable types) will automatically stop the engine before the oil level falls below the safe limit. However, to avoid the inconvenience of an unexpected shutdown, always check the engine oil level before startup.

Oil Change

Drain the used oil when the engine is warm. Warm oil drains quickly and completely.

1. Place a suitable container below the engine to catch the used oil, then remove the oil filler cap/dipstick, oil drain plug and washer.
2. Allow the used oil to drain completely, then reinstall the oil drain plug and new washer, and tighten the oil drain plug securely.

Please dispose of used motor oil in a manner that is compatible with the environment. We suggest you take used oil in a sealed container to your local recycling center or service station for reclamation. Do not throw it in the trash, pour it on the ground, or pour it down a drain.

3. With the engine in a level position, fill with the recommended oil (see page 8) to the upper limit mark (bottom edge of the oil fill hole) on the dipstick.

NOTICE

Running the engine with a low oil level can cause engine damage. This type of damage is not covered by the Distributor's Limited Warranty.

The Oil Alert system (applicable types) will automatically stop the engine before the oil level falls below the safe limit. However, to avoid the inconvenience of an unexpected shutdown, fill to the upper limit, and check the oil level regularly.

4. Install the oil filler cap/dipstick and tighten securely.

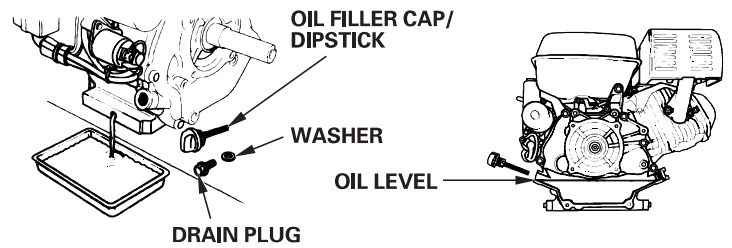

REDUCTION CASE OIL (applicable types)

Recommended Oil

Use the same oil that is recommended for the engine (see page 8).

Oil Level Check

Check the reduction case oil level with the engine stopped and in a level position.

2 : 1 Reduction Case With Centrifugal Clutch

1. Remove the oil filler cap/dipstick and wipe it clean.
2. Insert and remove the oil filler cap/dipstick without screwing it into the filler hole. Check the oil level shown on the oil filler cap/dipstick.
3. If the oil level is low, add the recommended oil to reach the upper limit mark on the dipstick.
4. Screw in the oil filler cap/dipstick and tighten securely.

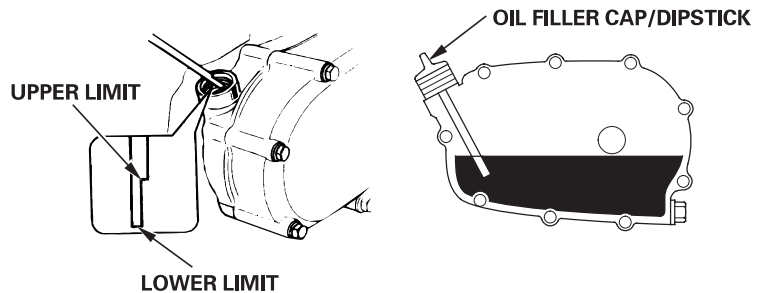

Oil Change

Drain the used oil while the engine is warm. Warm oil drains quickly and completely.

1. Place a suitable container below the reduction case to catch the used oil, then remove the oil filler cap/dipstick, the drain plug and washer.
2. Allow the used oil to drain completely, then reinstall the drain plug and a new washer, and tighten it securely.

Please dispose of used motor oil in a manner that is compatible with the environment. We suggest you take used oil in a sealed container to your local recycling center or service station for reclamation. Do not throw it in the trash or pour it on the ground or down a drain.

3. With the engine in a level position, fill to the upper limit mark on the dipstick with the recommended oil (see page 9). To check the oil level, insert and remove the dipstick without screwing it into the filler hole.

Transmission oil capacity: 0.30 l (0.32 US qt , 0.26 Imp qt)

NOTICE

Running the engine with a low transmission oil level can cause transmission damage.

4. Screw in the oil filler cap/dipstick and tighten securely.

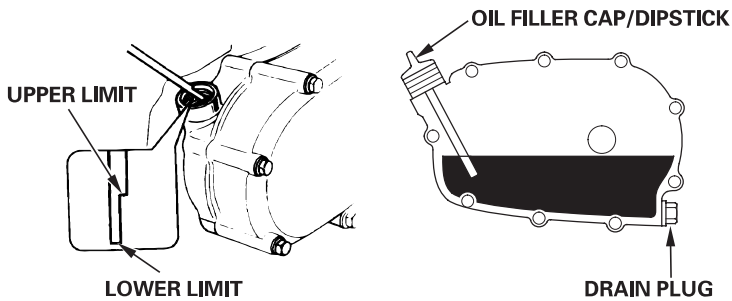

AIR CLEANER

A dirty air cleaner will restrict air flow to the carburetor, reducing engine performance. If you operate the engine in very dusty areas, clean the air filter more often than specified in the MAINTENANCE SCHEDULE.

NOTICE

Operating the engine without an air filter, or with a damaged air filter, will allow dirt to enter the engine, causing rapid engine wear. This type of damage is not covered by the Distributor's Limited Warranty.

Inspection

Remove the air cleaner cover and inspect the filter elements. Clean or replace dirty filter elements. Always replace damaged filter elements. If equipped with an oil-bath air cleaner, also check the oil level.

Refer to pages 10 – 11 for instructions that apply to the air cleaner and filter for your engine type.

Cleaning

Dual-Filter-Element Types

1. Remove the wing nut from the air cleaner cover, and remove the cover.
2. Remove the wing nut from the air filter, and remove the filter.
3. Remove the foam filter from the paper filter.
4. Inspect both air filter elements, and replace them if they are damaged. Always replace the paper air filter element at the scheduled interval (see page 7).

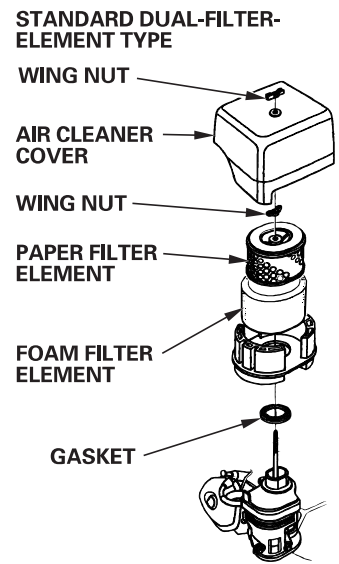

Cyclone Dual-Filter-Element Type

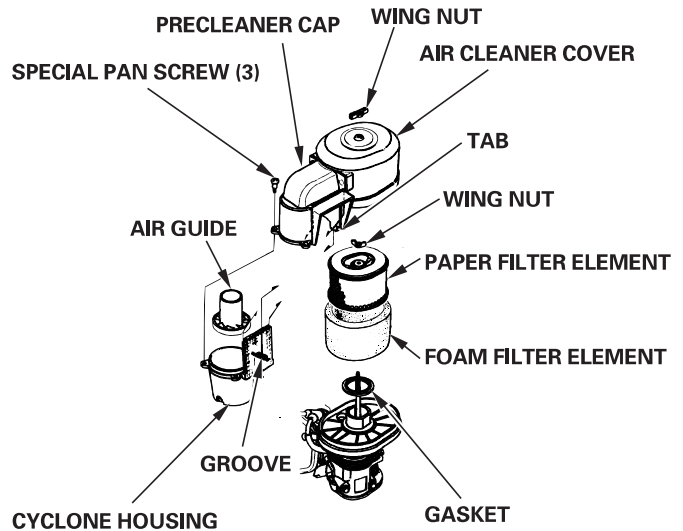

5. Clean the air filter elements if they are to be reused.

Paper air filter element: Tap the filter element several times on a hard surface to remove dirt, or blow compressed air [not exceeding 207 kPa (2.1 kgf/cm², 30 psi)] through the filter element from the inside. Never try to brush off dirt; brushing will force dirt into the fibers.

Foam air filter element: Clean in warm soapy water, rinse, and allow to dry thoroughly. Or clean in non-flammable solvent and allow to dry. Dip the filter element in clean engine oil, then squeeze out all excess oil. The engine will smoke when started if too much oil is left in the foam.

6. **CYCLONE TYPE ONLY:** Remove the three pan-head screws from the pre-cleaner cap, then remove the cyclone housing and air guide. Wash the parts with water, dry them thoroughly, and reassemble them.

Be sure to install the air guide as shown in the illustration.

Install the cyclone housing so the air intake tab fits into the groove in the pre-cleaner cap.

7. Wipe dirt from the inside of the air cleaner case and cover using a moist rag. Be careful to prevent dirt from entering the air duct that leads to the carburetor.

8. Place the foam air filter element over the paper element, and reinstall the assembled air filter. Be sure the gasket is in place beneath the air filter. Tighten the air filter wing nut securely.

9. Install the air cleaner cover, and tighten the wing nut securely.

Oil Bath & Single-Filter-Element Types

1. Remove the wing nut, and remove the air cleaner cap and cover.

2. Remove the air filter element from the cover. Wash the cover and filter element in warm soapy water, rinse, and allow to dry thoroughly. Or clean in non-flammable solvent and allow to dry.

3. Dip the filter element in clean engine oil, then squeeze out all excess oil. The engine will smoke if too much oil is left in the foam.

4. **OIL BATH TYPE ONLY:** Empty the used oil from the air cleaner case, wash out any accumulated dirt with non-flammable solvent, and dry the case.

5. **OIL BATH TYPE ONLY:** Fill the air cleaner case to the **OIL LEVEL** mark with the same oil that is recommended for the engine (see page 8).

Oil capacities:

GX240/GX270: 60 cm³ (2.0 US oz, 2.1 Imp oz)

GX340/GX390: 80 cm³ (2.7 US oz, 2.8 Imp oz)

6. Reassemble the air cleaner, and tighten the wing nut securely.

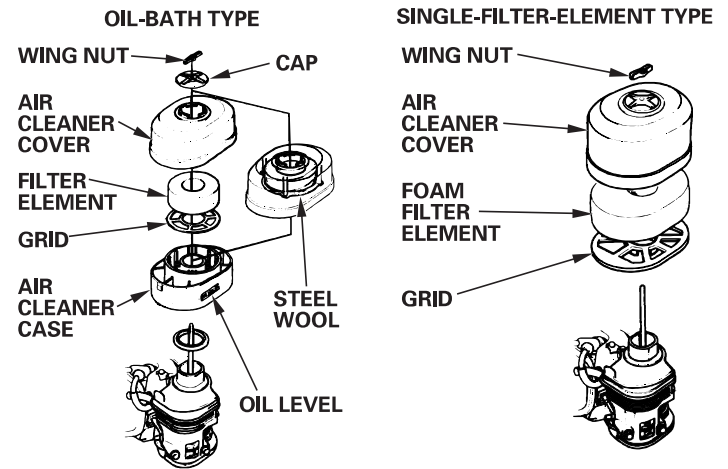

Low Profile Types

1. Unsnap the air cleaner cover clips, remove the air cleaner cover, and remove the air filter element.

2. Wash the element in a solution of household detergent and warm water, then rinse thoroughly, or wash in non-flammable or high flash point solvent. Allow the element to dry thoroughly.

3. Soak the air filter element in clean engine oil and squeeze out the excess oil. The engine will smoke during initial startup if too much oil is left in the element.

4. Reinstall the air filter element and the cover.

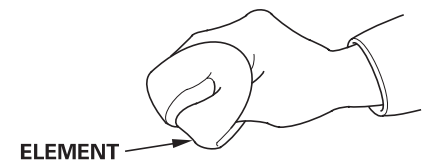
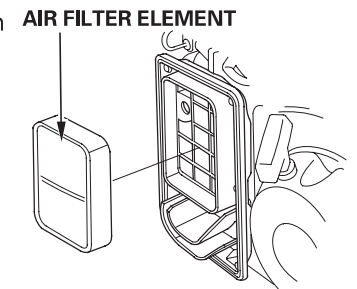
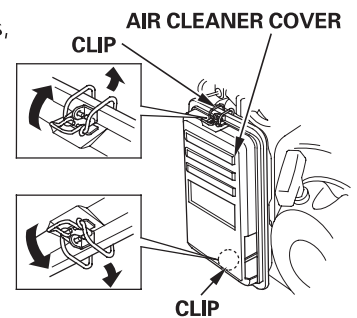

SEDIMENT CUP

Cleaning

⚠ WARNING

Gasoline is highly flammable and explosive, and you can be burned or seriously injured when handling fuel.

- Stop engine and keep heat, sparks, and flame away.
- Handle fuel only outdoors.
- Wipe up spills immediately.

1. Move the fuel valve to the OFF position, then remove the fuel sediment cup and O-ring.
2. Wash the sediment cup in non-flammable solvent, and dry it thoroughly.

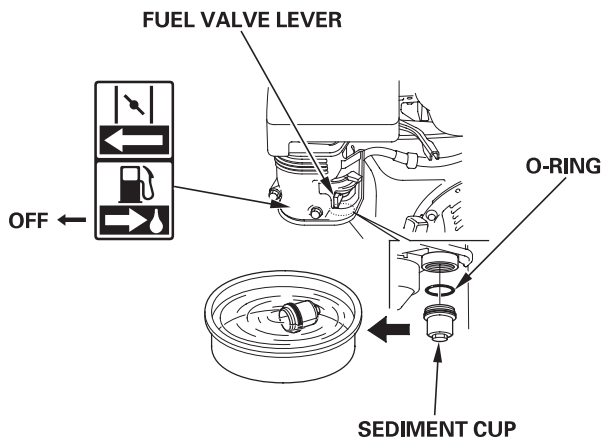

3. Place the O-ring in the fuel valve, and install the sediment cup. Tighten the sediment cup securely.
4. Move the fuel valve to the ON position, and check for leaks. Replace the O-ring if there is any leakage.

SPARK PLUG

Recommended Spark Plugs: BPR6ES (NGK)
W20EPR-U (DENSO)

The recommended spark plug has the correct heat range for normal engine operating temperatures.

NOTICE

An incorrect spark plug can cause engine damage.

For good performance, the spark plug must be properly gapped and free of deposits.

1. Disconnect the spark plug cap, and remove any dirt from around the spark plug area.
2. Remove the spark plug with a 13/16-inch spark plug wrench.
3. Inspect the spark plug. Replace it if damaged or badly fouled, if the sealing washer is in poor condition, or if the electrode is worn.

SPARK PLUG WRENCH

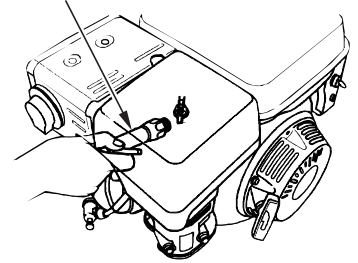

4. Measure the spark plug electrode gap with a wire-type feeler gauge. Correct the gap, if necessary, by carefully bending the side electrode. The gap should be:
0.70–0.80 mm (0.028–0.031 in)

SIDE ELECTRODE

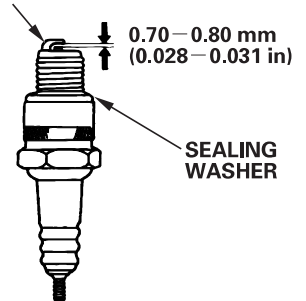

5. Install the spark plug carefully, by hand, to avoid cross-threading.
6. After the spark plug is seated, tighten with a 13/16-inch spark plug wrench to compress the sealing washer.
7. When installing a new spark plug, tighten 1/2 turn after the spark plug seats to compress the washer.
8. When reinstalling the original spark plug, tighten 1/8–1/4 turn after the spark plug seats to compress the washer.

NOTICE

A loose spark plug can overheat and damage the engine. Overtightening the spark plug can damage the threads in the cylinder head.

9. Attach the spark plug cap to the spark plug.

SPARK ARRESTER (applicable types)

The spark arrester may be standard or an optional part, depending on the engine type. In some areas, it is illegal to operate an engine without a spark arrester. Check local laws and regulations. A spark arrester is available from authorized Honda servicing dealers.

The spark arrester must be serviced every 100 hours to keep it functioning as designed.

If the engine has been running, the muffler will be hot. Allow it to cool before servicing the spark arrester.

Spark Arrester Removal

1. Remove the two 8 mm nuts and remove the muffler from the cylinder.
2. Remove the three 4 mm screws from the exhaust deflector, and remove the deflector.
3. Remove the four 5 mm screws from the muffler protector and remove the muffler protector.
4. Remove the 4 mm screw from the spark arrester, and remove the spark arrester from the muffler.

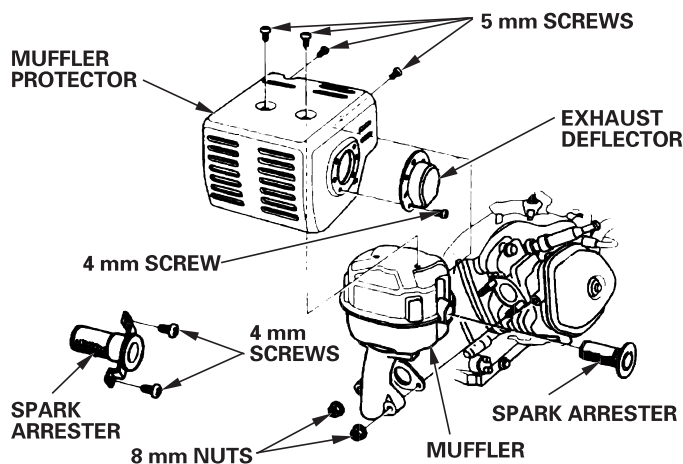

Spark Arrester Cleaning & Inspection

1. Use a brush to remove carbon deposits from the spark arrester screen. Be careful not to damage the screen. Replace the spark arrester if it has breaks or holes.
2. Install the spark arrester, muffler protector, exhaust deflector and muffler in the reverse order of disassembly.

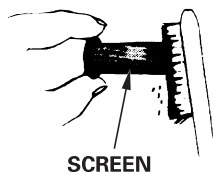

IDLE SPEED

Adjustment

1. Start the engine outdoors, and allow it to warm up to operating temperature.
2. Move the throttle lever to its minimum position.
3. Turn the throttle stop screw to obtain the standard idle speed.

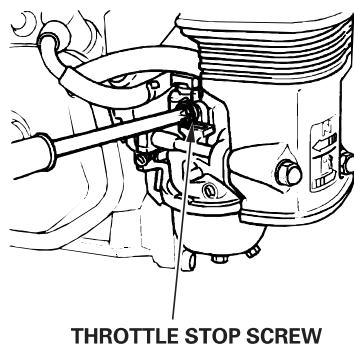

Standard idle speed: 1,400 ± 150 rpm

HELPFUL TIPS & SUGGESTIONS

STORING YOUR ENGINE

Storage Preparation

Proper storage preparation is essential for keeping your engine trouble-free and looking good. The following steps will help to keep rust and corrosion from impairing your engine's function and appearance, and will make the engine easier to start when you use it again.

Cleaning

If the engine has been running, allow it to cool for at least half an hour before cleaning. Clean all exterior surfaces, touch up any damaged paint, and coat other areas that may rust with a light film of oil.

NOTICE

Using a garden hose or pressure washing equipment can force water into the air cleaner or muffler opening. Water in the air cleaner will soak the air filter, and water that passes through the air filter or muffler can enter the cylinder, causing damage.

Fuel

Gasoline will oxidize and deteriorate in storage. Deteriorated gasoline will cause hard starting, and it leaves gum deposits that clog the fuel system. If the gasoline in your engine deteriorates during storage, you may need to have the carburetor, and other fuel system components, serviced or replaced.

The length of time that gasoline can be left in your fuel tank and carburetor without causing functional problems will vary with such factors as gasoline blend, your storage temperatures, and whether the fuel tank is partially or completely filled. The air in a partially filled fuel tank promotes fuel deterioration. Very warm storage temperatures accelerate fuel deterioration. Fuel problems may occur within a few months, or even less if the gasoline was not fresh when you filled the fuel tank.

Fuel system damage or engine performance problems resulting from neglected storage preparation are not covered under the *Distributor's Limited Warranty*.

You can extend fuel storage life by adding a gasoline stabilizer that is formulated for that purpose, or you can avoid fuel deterioration problems by draining the fuel tank and carburetor.

Adding a Gasoline Stabilizer to Extend Fuel Storage Life

When adding a gasoline stabilizer, fill the fuel tank with fresh gasoline. If only partially filled, air in the tank will promote fuel deterioration during storage. If you keep a container of gasoline for refueling, be sure that it contains only fresh gasoline.

1. Add gasoline stabilizer following the manufacturer's instructions.
2. After adding a gasoline stabilizer, run the engine outdoors for 10 minutes to be sure that treated gasoline has replaced the untreated gasoline in the carburetor.
3. Stop the engine.

Draining the Fuel Tank and Carburetor

⚠ WARNING

Gasoline is highly flammable and explosive, and you can be burned or seriously injured when handling fuel.

- Stop engine and keep heat, sparks, and flame away.
- Handle fuel only outdoors.
- Wipe up spills immediately.

1. Place an approved gasoline container below the carburetor, and use a funnel to avoid spilling fuel.
2. Remove the carburetor drain bolt and gasket. Remove the sediment cup and O-ring, then move the fuel valve lever to the ON position.

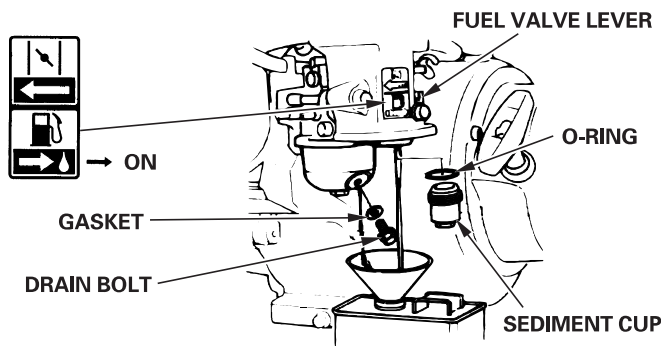

3. After all the fuel has drained into the container, reinstall the drain bolt, gasket, sediment cup and O-ring. Tighten the drain bolt and sediment cup securely.

Engine Oil

1. Change the engine oil (see page 9).
2. Remove the spark plug (see page 12).
3. Pour a tablespoon 5–10 cm³ (5–10 cc) of clean engine oil into the cylinder.
4. Pull the starter rope several times to distribute the oil in the cylinder.
5. Reinstall the spark plug.
6. Pull the starter rope slowly until resistance is felt and the notch on the starter pulley aligns with the hole at the top of the recoil starter cover. This will close the valves so moisture cannot enter the engine cylinder. Return the starter rope gently.

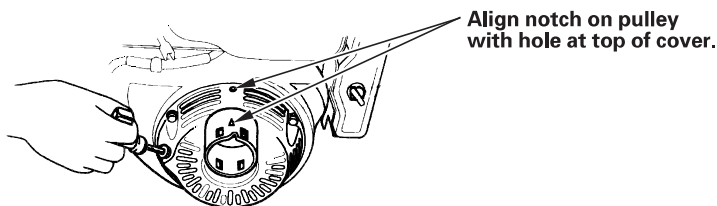

Storage Precautions

If your engine will be stored with gasoline in the fuel tank and carburetor, it is important to reduce the hazard of gasoline vapor ignition. Select a well-ventilated storage area away from any appliance that operates with a flame, such as a furnace, water heater, or clothes dryer. Also avoid any area with a spark-producing electric motor, or where power tools are operated.

If possible, avoid storage areas with high humidity, because that promotes rust and corrosion.

Keep the engine level in storage. Tilting can cause fuel or oil leakage.

With the engine and exhaust system cool, cover the engine to keep out dust. A hot engine and exhaust system can ignite or melt some materials. Do not use sheet plastic as a dust cover. A nonporous cover will trap moisture around the engine, promoting rust and corrosion.

If equipped with a battery for electric starter types, recharge the battery once a month while the engine is in storage. This will help to extend the service life of the battery.

Removal from Storage

Check your engine as described in the *BEFORE OPERATION CHECKS* section of this manual (see page 3).

If the fuel was drained during storage preparation, fill the tank with fresh gasoline. If you keep a container of gasoline for refueling, be sure it contains only fresh gasoline. Gasoline oxidizes and deteriorates over time, causing hard starting.

If the cylinder was coated with oil during storage preparation, the engine will smoke briefly at startup. This is normal.

TRANSPORTING

If the engine has been running, allow it to cool for at least 15 minutes before loading the engine-powered equipment on the transport vehicle. A hot engine and exhaust system can burn you and can ignite some materials.

Keep the engine level when transporting to reduce the possibility of fuel leakage. Turn the fuel valve to the OFF position (see page 5).

TAKING CARE OF UNEXPECTED PROBLEMS

ENGINE WILL NOT START	Possible Cause	Correction
1. Electric starting (applicable types): Check battery and fuse.	Battery discharged.	Recharge battery.
	Fuse burnt out.	Replace fuse. (p. 15).
2. Check control positions.	Fuel valve OFF.	Move lever to ON position.
	Choke open.	Move lever to CLOSED position unless the engine is warm.
	Engine switch OFF.	Turn engine switch to ON position.
3. Check engine oil level.	Engine oil level low (Oil Alert models).	Fill with the recommended oil to the proper level (p. 9).
4. Check fuel.	Out of fuel.	Refuel (p. 8).
	Bad fuel; engine stored without treating or draining gasoline, or refueled with bad gasoline.	Drain fuel tank and carburetor (p. 14). Refuel with fresh gasoline (p. 8).
5. Remove and inspect spark plug.	Spark plug faulty, fouled, or improperly gapped.	Gap or replace spark plug (p. 12).
	Spark plug wet with fuel (flooded engine).	Dry and reinstall spark plug. Start engine with throttle lever in MAX. position.
6. Take engine to an authorized Honda servicing dealer, or refer to shop manual.	Fuel filter restricted, carburetor malfunction, ignition malfunction, valves stuck, etc.	Replace or repair faulty components as necessary.

ENGINE LACKS POWER	Possible Cause	Correction
1. Check air filter.	Filter element(s) restricted.	Clean or replace filter element(s) (p. 10–11).
2. Check fuel.	Bad fuel; engine stored without treating or draining gasoline, or refueled with bad gasoline.	Drain fuel tank and carburetor (p. 14). Refuel with fresh gasoline (p. 8).
3. Take engine to an authorized Honda servicing dealer, or refer to shop manual.	Fuel filter restricted, carburetor malfunction, ignition malfunction, valves stuck, etc.	Replace or repair faulty components as necessary.

FUSE REPLACEMENT (applicable types)

The electric starter relay circuit and battery charging circuit are protected by a fuse. If the fuse burns out, the electric starter will not operate. The engine can be started manually if the fuse burns out, but running the engine will not charge the battery.

1. Remove the 6 × 12 mm screw from the rear cover of the engine switch box.
2. Remove the fuse cover, then pull out and inspect the fuse.

If the fuse is burnt out, discard the burnt-out fuse. Install a new fuse with the same rating as the one that was removed, and reinstall the cover.

If you have questions regarding the rating of the original fuse, contact your servicing Honda engine dealer.

NOTICE

Never use a fuse with a rating greater than the one originally equipped with the engine. Serious damage to the electrical system or a fire could result.

3. Reinstall the rear cover. Install the 6 × 12 mm screw and tighten it securely.

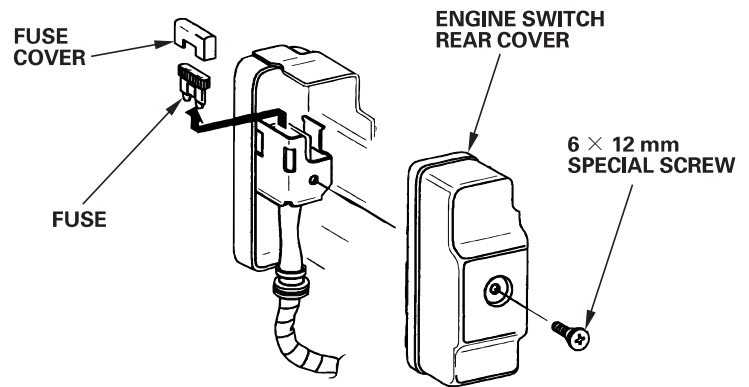

Frequent fuse failure usually indicates a short circuit or an overload in the electrical system. If the fuse burns out frequently, take the engine to a servicing Honda dealer for repair.

TECHNICAL & CONSUMER INFORMATION

TECHNICAL INFORMATION

Serial Number Location

Record the engine serial number in the space below. You will need this information when ordering parts and when making technical or warranty inquiries.

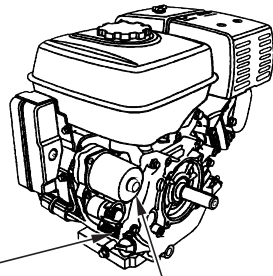

SERIAL NUMBER & ENGINE TYPE LOCATION

ELECTRIC STARTER (applicable types)

Engine serial number: _____

Engine type: _____

Date Purchased: ____ / ____ / ____

Battery Connections for Electric Starter (applicable types)

Use a 12-volt battery with an ampere-hour rating of at least 18 Ah.

Be careful not to connect the battery in reverse polarity, as this will short circuit the battery charging system. Always connect the positive (+) battery cable to the battery terminal before connecting the negative (-) battery cable, so your tools cannot cause a short circuit if they touch a grounded part while tightening the positive (+) battery cable end.

⚠ WARNING

A battery can explode if you do not follow the correct procedure, seriously injuring anyone nearby.

Keep all sparks, open flames, and smoking materials away from the battery.

1. Connect the battery positive (+) cable to the starter solenoid terminal as shown.
2. Connect the battery negative (-) cable to an engine mounting bolt, frame bolt, or other good engine ground connection.
3. Connect the battery positive (+) cable to the battery positive (+) terminal as shown.
4. Connect the battery negative (-) cable to the battery negative (-) terminal as shown.
5. Coat the terminals and cable ends with grease.

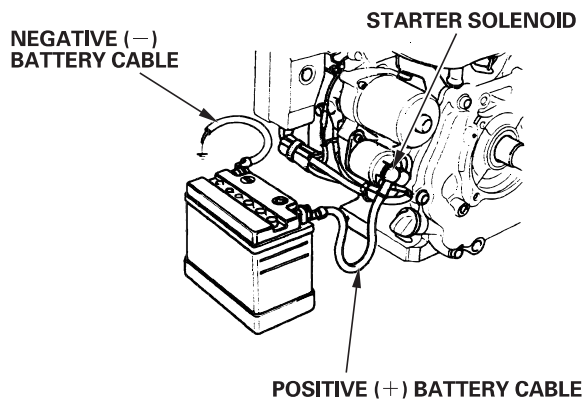

Remote Control Linkage

The throttle and choke control levers are provided with holes for optional cable attachment. The following illustrations show installation examples for a solid wire cable and for a flexible, braided wire cable. If using a flexible, braided wire cable, add a return spring as shown.

It is necessary to loosen the throttle lever friction nut when operating the throttle with a remote-mounted control.

REMOTE THROTTLE LINKAGE

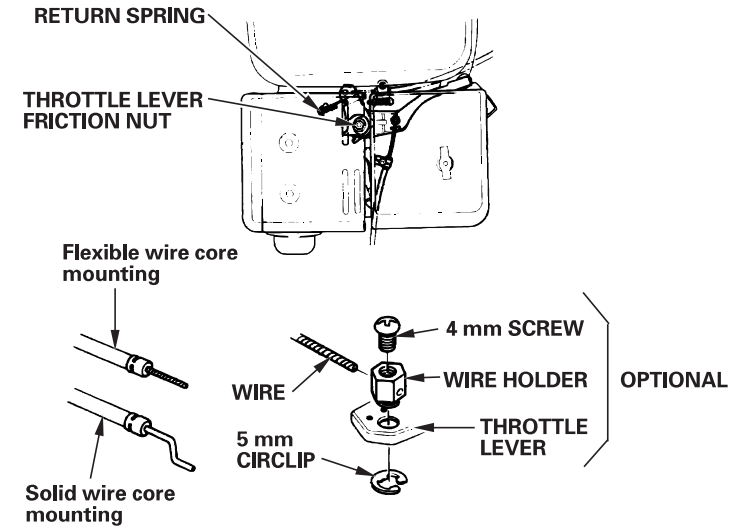

REMOTE CHOKE LINKAGE

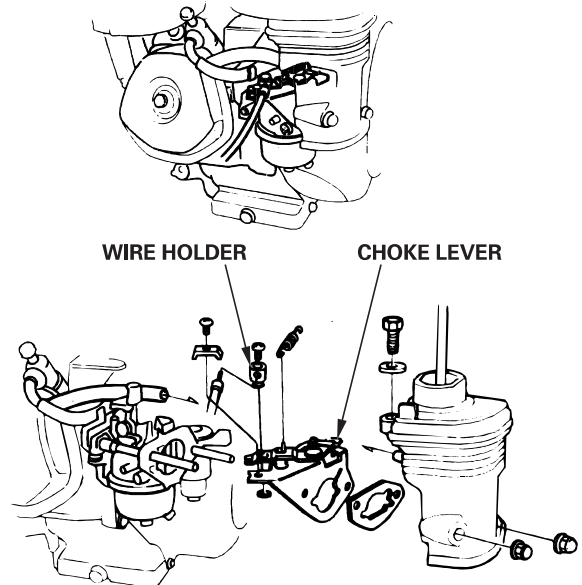

Carburetor Modifications for High Altitude Operation

At high altitude, the standard carburetor air-fuel mixture will be too rich. Performance will decrease, and fuel consumption will increase. A very rich mixture will also foul the spark plug and cause hard starting. Operation at an altitude that differs from that at which this engine was certified, for extended periods of time, may increase emissions.

High altitude performance can be improved by specific modifications to the carburetor. If you always operate your engine at altitudes above 1,500 meters (5,000 feet), have your servicing dealer perform this carburetor modification. This engine, when operated at high altitude with the carburetor modifications for high altitude use, will meet each emission standard throughout its useful life.

Even with carburetor modification, engine horsepower will decrease about 3.5% for each 300-meter (1,000-foot) increase in altitude. The effect of altitude on horsepower will be greater than this if no carburetor modification is made.

NOTICE

When the carburetor has been modified for high altitude operation, the air-fuel mixture will be too lean for low altitude use. Operation at altitudes below 1,500 meters (5,000 feet) with a modified carburetor may cause the engine to overheat and result in serious engine damage. For use at low altitudes, have your servicing dealer return the carburetor to original factory specifications.

Emission Control System Information

Source of Emissions

The combustion process produces carbon monoxide, oxides of nitrogen, and hydrocarbons. Control of hydrocarbons and oxides of nitrogen is very important because, under certain conditions, they react to form photochemical smog when subjected to sunlight. Carbon monoxide does not react in the same way, but it is toxic.

Honda utilizes lean carburetor settings and other systems to reduce the emissions of carbon monoxide, oxides of nitrogen, and hydrocarbons.

The U.S., California Clean Air Acts and Environment Canada
EPA, California and Canadian regulations require all manufacturers to furnish written instructions describing the operation and maintenance of emission control systems.

The following instructions and procedures must be followed in order to keep the emissions from your Honda engine within the emission standards.

Tampering and Altering

Tampering with or altering the emission control system may increase emissions beyond the legal limit. Among those acts that constitute tampering are:

- Removal or alteration of any part of the intake, fuel, or exhaust systems.
- Altering or defeating the governor linkage or speed-adjusting mechanism to cause the engine to operate outside its design parameters.

Problems That May Affect Emissions

If you are aware of any of the following symptoms, have your engine inspected and repaired by your servicing dealer.

- Hard starting or stalling after starting.
- Rough idle.
- Misfiring or backfiring under load.
- Afterburning (backfiring).
- Black exhaust smoke or high fuel consumption.

Replacement Parts

The emission control systems on your Honda engine were designed, built, and certified to conform with EPA, California and Canadian emission regulations. We recommend the use of genuine Honda parts whenever you have maintenance done. These original-design replacement parts are manufactured to the same standards as the original parts, so you can be confident of their performance. The use of replacement parts that are not of the original design and quality may impair the effectiveness of your emission control system.

A manufacturer of an aftermarket part assumes the responsibility that the part will not adversely affect emission performance. The manufacturer or rebuilder of the part must certify that use of the part will not result in a failure of the engine to comply with emission regulations.

Maintenance

Follow the maintenance schedule on page 7. Remember that this schedule is based on the assumption that your machine will be used for its designed purpose. Sustained high-load or high-temperature operation, or use in unusually wet or dusty conditions, will require more frequent service.

Air Index

An Air Index Information hang tag/label is applied to engines certified to an emission durability time period in accordance with the requirements of the California Air Resources Board.

The bar graph is intended to provide you, our customer, the ability to compare the emissions performance of available engines. The lower the Air Index, the less pollution.

The durability description is intended to provide you with information relating to the engine's emission durability period. The descriptive term indicates the useful life period for the engine's emission control system. See your *Emission Control System Warranty* for additional information.

Descriptive Term	Applicable to Emissions Durability Period
Moderate	50 hours [0–65 cm ³ (0–65 cc)] 125 hours [greater than 65 cm ³ (65 cc)]
Intermediate	125 hours [0–65 cm ³ (0–65 cc)] 250 hours [greater than 65 cm ³ (65 cc)]
Extended	300 hours [0–65 cm ³ (0–65 cc)] 500 hours [greater than 65 cm ³ (65 cc)]

The Air Index Information hang tag/label must remain on the engine until it is sold. Remove the hang tag before operating the engine.

Specifications

GX240/GX270 (PTO shaft type S)

Length × Width × Height	355 × 430 × 410 mm (14.0 × 16.9 × 16.1 in)	
Dry mass [weight]	25.0 kg (55.1 lbs)	
Engine type	4-stroke, overhead valve, single cylinder	
Displacement [Bore × Stroke]	GX240	242 cm ³ (14.8 cu-in) [73.0 × 58.0 mm (2.9 × 2.3 in)]
	GX270	270 cm ³ (16.5 cu-in) [77.0 × 58.0 mm (3.0 × 2.3 in)]
Net power (in accordance with SAE J1349*)	GX240	5.3 kW (7.2 PS, 7.1 bhp) at 3,600 rpm
	GX270	6.0 kW (8.2 PS, 8.0 bhp) at 3,600 rpm
Max. Net torque (in accordance with SAE J1349*)	GX240	15.3 N·m (1.56 kgf·m, 11.3 lbf·ft) at 2,500 rpm
	GX270	17.7 N·m (1.80 kgf·m, 13.1 lbf·ft) at 2,500 rpm
Engine oil capacity	1.1 ℓ (1.2 US qt, 1.0 Imp qt)	
Fuel tank capacity	5.3 ℓ (1.40 US gal, 1.17 Imp gal)	
Cooling system	Forced air	
Ignition system	Transistor magneto	
PTO shaft rotation	Counterclockwise	

GX340/GX390 (PTO shaft type S)

Length × Width × Height	380 × 450 × 443 mm (15.0 × 17.7 × 17.4 in)	
Dry mass [weight]	31.5 kg (69.4 lbs)	
Engine type	4-stroke, overhead valve, single cylinder	
Displacement [Bore × Stroke]	GX340	337 cm ³ (20.6 cu-in) [82.0 × 64.0 mm (3.2 × 2.5 in)]
	GX390	389 cm ³ (23.7 cu-in) [88.0 × 64.0 mm (3.5 × 2.5 in)]
Net power (in accordance with SAE J1349*)	GX340	7.1 kW (9.7 PS, 9.5 bhp) at 3,600 rpm
	GX390	8.2 kW (11.1 PS, 11.0 bhp) at 3,600 rpm
Max. Net torque (in accordance with SAE J1349*)	GX340	22.1 N·m (2.25 kgf·m, 16.3 lbf·ft) at 2,500 rpm
	GX390	25.1 N·m (2.56 kgf·m, 18.5 lbf·ft) at 2,500 rpm
Engine oil capacity	1.1 ℓ (1.2 US qt, 1.0 Imp qt)	
Fuel tank capacity	6.1 ℓ (1.61 US gal, 1.34 Imp gal)	
Cooling system	Forced air	
Ignition system	Transistor magneto	
PTO shaft rotation	Counterclockwise	

* The power rating of the engine indicated in this document is the net power output tested on a production engine for the engine model and measured in accordance with SAE J1349 at 3,600 rpm (Net Power) and at 2,500 rpm (Max. Net Torque). Mass production engines may vary from this value. Actual power output for the engine installed in the final machine will vary depending on numerous factors, including the operating speed of the engine in application, environmental conditions, maintenance, and other variables.

Tuneup Specifications GX240/GX270/GX340/GX390

ITEM	SPECIFICATION	MAINTENANCE
Spark plug gap	0.70–0.80 mm (0.028–0.031 in)	Refer to page: 12
Idle speed	1,400 ± 150 rpm	Refer to page: 13
Valve clearance (cold)	IN: 0.15 ± 0.02 mm EX: 0.20 ± 0.02 mm	See your authorized Honda dealer
Other specifications	No other adjustments needed.	

Quick Reference Information

Fuel	Unleaded gasoline (Refer to page 8)	
	U.S.	Pump octane rating 86 or higher
	Except U.S.	Research octane rating 91 or higher
	U.S.	Pump octane rating 86 or higher
Engine oil	SAE 10W-30, API SJ or later, for general use. Refer to page 8.	
Reduction case oil	Same oil as engine oil, see above (applicable types).	
Spark plug	BPR6ES (NGK) W20EPR-U (DENSO)	
Maintenance	Before each use:	
	<ul style="list-style-type: none"> • Check engine oil level. Refer to page 9. • Check reduction case oil (applicable types). Refer to page 9. • Check air filter. Refer to page 10. 	
	First 20 hours:	
	<ul style="list-style-type: none"> • Change engine oil. Refer to page 9. • Change reduction case oil (applicable types). Refer to page 10. 	
	Subsequent: Refer to the maintenance schedule on page 7.	

Wiring Diagrams

With Oil Alert® and Electric Starter

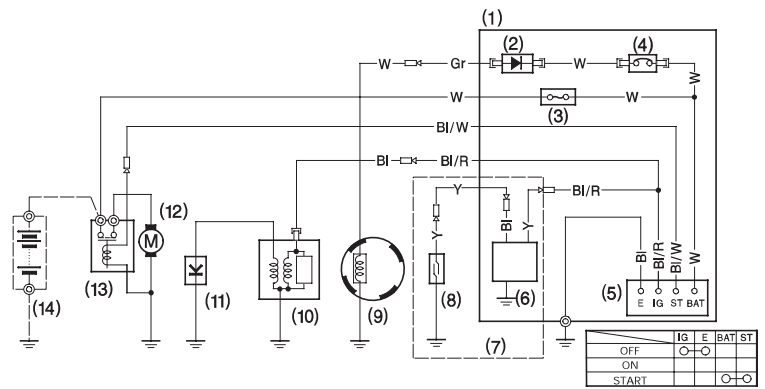

With Oil Alert® and Without Electric Starter

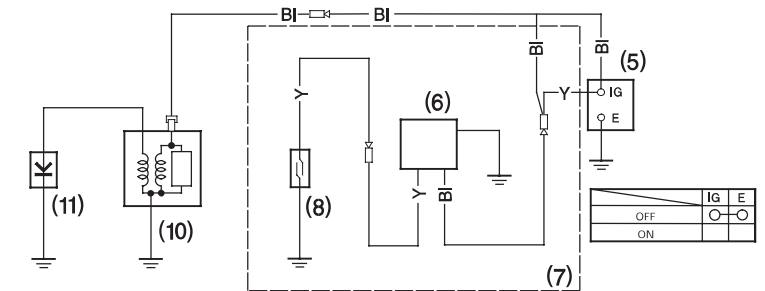

- | | |
|------------------------------|-----------------------|
| (1) CONTROL BOX | (8) OIL LEVEL SWITCH |
| (2) RECTIFIER | (9) CHARGING COIL |
| (3) FUSE | (10) IGNITION COIL |
| (4) CIRCUIT BREAKER | (11) SPARK PLUG |
| (5) ENGINE SWITCH | (12) STARTER MOTOR |
| (6) OIL ALERT UNIT | (13) STARTER SOLENOID |
| (7) Type with Oil Alert unit | (14) BATTERY (12 V) |

Bl	Black	Br	Brown
Y	Yellow	O	Orange
Bu	Blue	Lb	Light blue
G	Green	Lg	Light green
R	Red	P	Pink
W	White	Gr	Gray

CONSUMER INFORMATION

Distributor/Dealer Locator Information

United States, Puerto Rico, and U.S. Virgin Islands:

Visit our website: www.honda-engines.com

Canada:

Call (888) 9HONDA9
or visit our website: www.honda.ca

For European Area:

visit our website: <http://www.honda-engines-eu.com>

Customer Service Information

Servicing dealership personnel are trained professionals. They should be able to answer any question you may have. If you encounter a problem that your dealer does not solve to your satisfaction, please discuss it with the dealership's management. The Service Manager, General Manager, or Owner can help. Almost all problems are solved in this way.

United States, Puerto Rico, and U.S. Virgin Islands:

If you are dissatisfied with the decision made by the dealership's management, contact the Honda Regional Engine Distributor for your area.

If you are still dissatisfied after speaking with the Regional Engine Distributor, you may contact the Honda's Office as shown.

All Other Areas:

If you are dissatisfied with the decision made by the dealership's management, contact the Honda's Office as shown.

《Honda's Office》

When you write or call, please provide this information:

- Equipment manufacturer's name and model number that the engine is mounted on
- Engine model, serial number, and type (see page 16)
- Name of dealer who sold the engine to you
- Name, address, and contact person of the dealer who services your engine
- Date of purchase
- Your name, address and telephone number
- A detailed description of the problem

United States, Puerto Rico, and U.S. Virgin Islands:

American Honda Motor Co., Inc.

Power Equipment Division
Customer Relations Office
4900 Marconi Drive
Alpharetta, GA 30005-8847

Or telephone: (770) 497-6400, 8:30 am - 7:00 pm EST

Canada:

Honda Canada, Inc.

715 Milner Avenue
Toronto, ON
M1B 2K8

Telephone: (888) 9HONDA9	Toll free
(888) 946-6329	
English: (416) 299-3400	Local Toronto dialing area
French: (416) 287-4776	Local Toronto dialing area
Facsimile: (877) 939-0909	Toll free
(416) 287-4776	Local Toronto dialing area

Australia:

Honda Australia Motorcycle and Power Equipment Pty. Ltd.

1954 – 1956 Hume Highway Campbellfield Victoria 3061

Telephone: (03) 9270 1111
Facsimile: (03) 9270 1133

For European Area:

Honda Europe NV.

European Engine Center

<http://www.honda-engines-eu.com>

All Other Areas:

Please contact the Honda distributor in your area for assistance.

HONDA
The Power of Dreams

(IT) POMPE ALTA PRESSIONE

(EN) HIGH PRESSURE PUMPS

(ES) BOMBAS DE ALTA PRESIÓN

(FR) POMPES HAUTE PRESSION

(DE) HOCHDRUCKPUMPEN

ITALIANO **IT**

ENGLISH **EN**

FRANÇAIS **FR**

ESPAÑOL **ES**

DEUTSCH **DE**

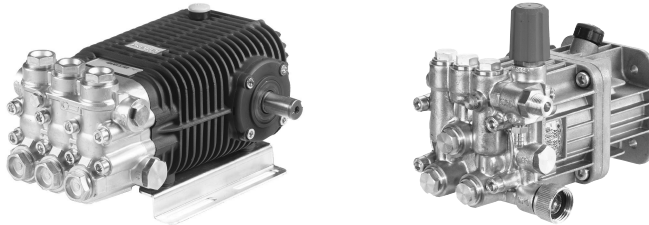

(IT) ISTRUZIONI PER L'ASSEMBLAGGIO USO E MANUTENZIONE

(EN) ASSEMBLY, OPERATION AND MAINTENANCE INSTRUCTIONS

**(FR) INSTRUCTIONS POUR L'ASSEMBLAGE - UTILISATION ET
ENTRETIEN**

(ES) INSTRUCCIONES PARA EL ENSAMBLAJE - USO Y MANTENIMIENTO

**(DE) ANWEISUNGEN FÜR DEN ZUSAMMENBAU, DIE BEDIENUNG
UND WARTUNG**



(IT) ATTENZIONE. Leggere le istruzioni prima dell'uso e dell'assemblaggio.

(EN) WARNING. Read the instructions before using and assembling.

(FR) ATTENTION. Lire les instructions avant d'utiliser et d'assembler l'appareil.

(ES) ATENCIÓN. Leer las instrucciones antes del uso y del ensamblaje.

(DE) ACHTUNG. Vor dem Gebrauch und dem Zusammenbau die Anweisungen lesen.



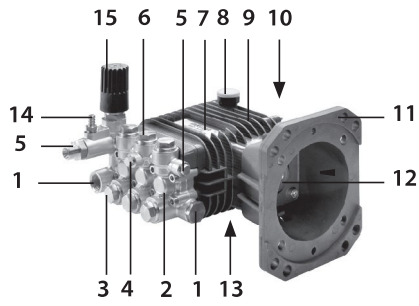

BW - AW

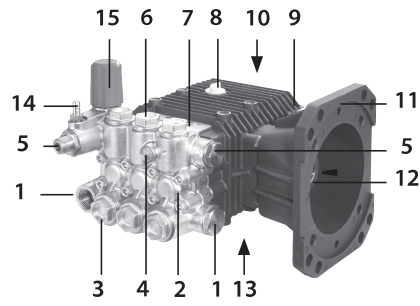

LW - ZW

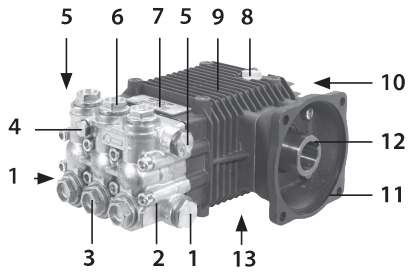

FW - FW2

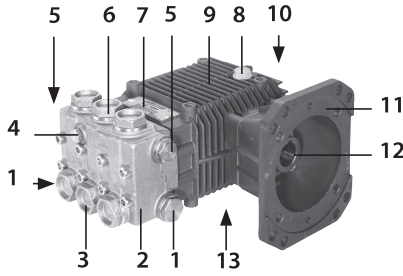

HW

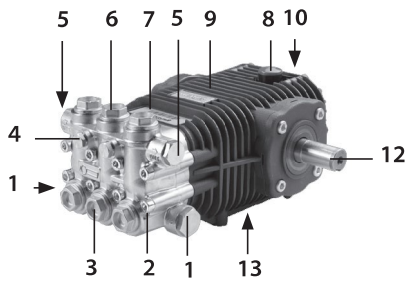

RW

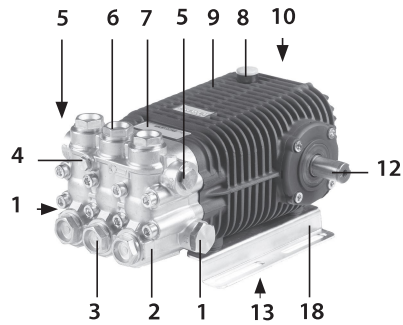

TW - SW

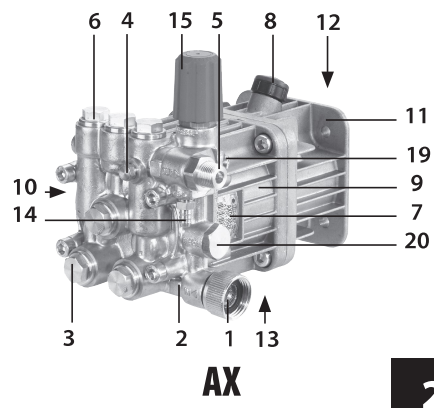
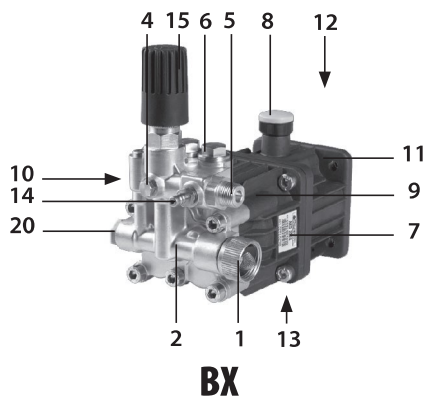

2

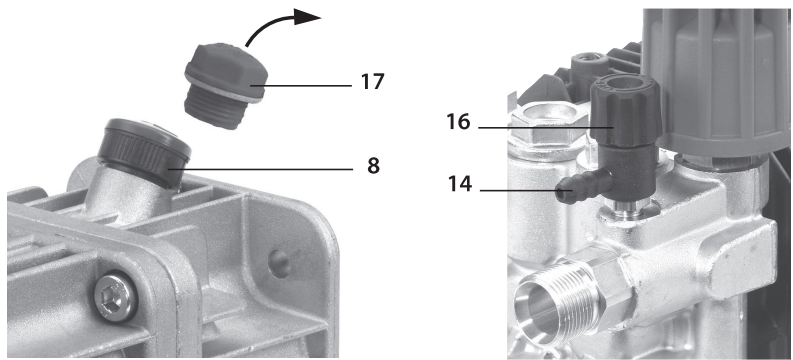

3

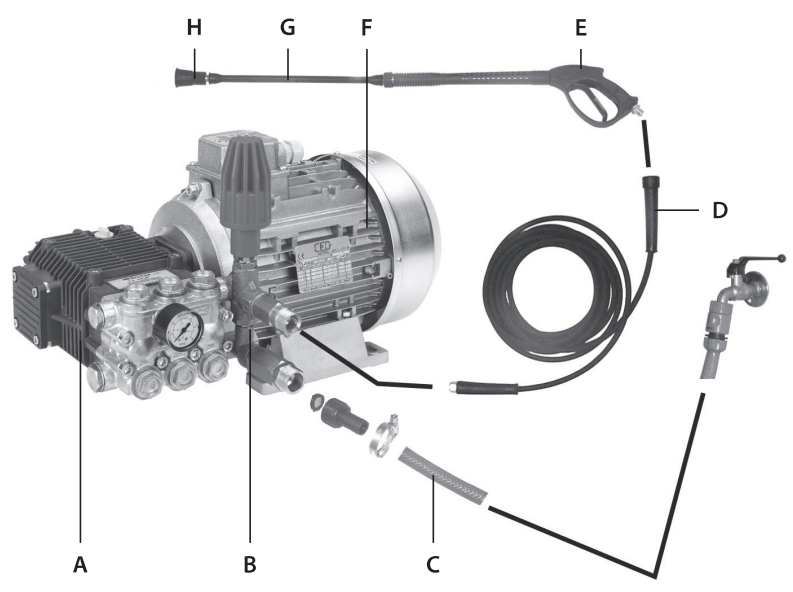

4

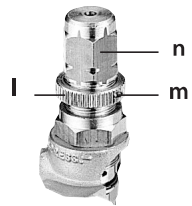
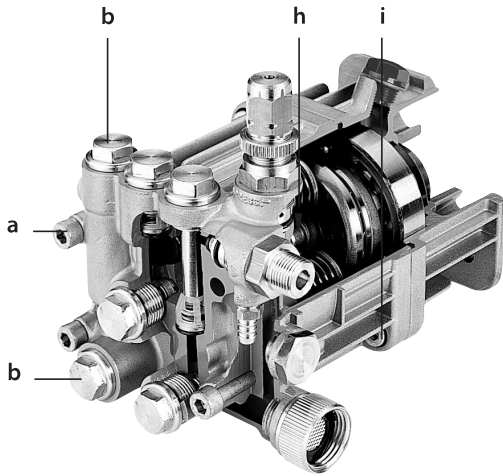
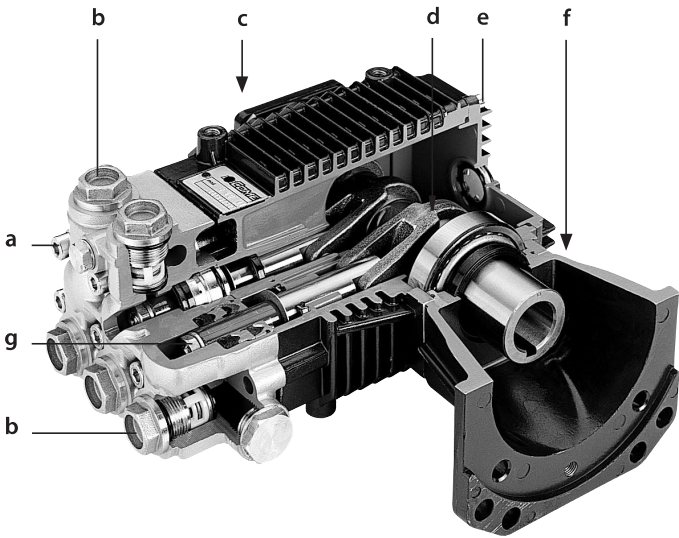

FOREWORD

This manual consists of two distinct parts.

The first is intended for both the end user and the **Skilled Technician** and contains the pump operation and maintenance instructions; the second is dedicated to the **Skilled Technician** only and provides instructions for the correct integration of the pump in the end machine and for special maintenance.

By **Skilled Technician** is meant:

- the Manufacturer of the machine (e.g., high pressure cleaner) in which the pump is integrated (from now on, when reference is made to “machine in which the pump is integrated”, this may also refer to “system in which the pump is integrated”, such as, for example, in the case of a pumping station);
- a person, normally belonging to the after-sales centre, specifically trained and authorised to perform special maintenance jobs and repairs on the pump and on the machine in which this is integrated. It should be remembered that jobs on the electrical parts must be performed by a **Skilled Technician** who is also a **Professional Electrician**, meaning a person professionally qualified and trained to check, install and repair electrical apparatus in a “workmanlike” manner and in accordance with the laws applicable in the country where the machine integrating the pump is installed.

PART ONE

GENERAL INFORMATION

Carefully read this manual and the manual of the machine in which the pump is integrated: **always carefully comply with the instructions contained in them.**

Special care must be given to reading the parts of the text marked by the symbol:



WARNING

inasmuch as these contain important safety instructions concerning pump operation.

The Manufacturer disclaims all liability relating to damage caused by:

- failure to abide by the contents of this manual and the manual of the machine in which the pump is integrated;
- the pump being used in ways other than those indicated in the “**INTENDED USE**” paragraph;
- the pump being used in ways contrary to applicable laws on safety and prevention of work accidents;
- tampering with the safety devices and with max operating pressure limitation;
- incorrect assembly and installation;
- incorrect maintenance;
- changes made or jobs done on the pump without the permission of the Manufacturer;
- use of non-original spare parts or which are not suitable for the pump model;
- repairs not performed by a **Skilled Technician**.

USING AND LOOKING AFTER THE MANUAL



WARNING

- *This manual completes that of the machine in which the pump is integrated: **read all the manuals carefully.***

The manual must be deemed an integral part of the pump and must be looked after for future reference and kept in a protected place where it can easily be referred to in case of need.

The manual contains safety precautions for the operator and those surrounding him/her and for the protection of the environment.

In case of deterioration or loss, a new copy must be requested from the Manufacturer or from a **Skilled Technician**.

In the event of the machine in which the pump is integrated being transferred to another user, please also include this manual.

The Manufacturer reserves the right to make all the amendments required to update and correct this publication without prior notice.

SYMBOLS

The symbol:



marking certain parts of the text indicates a likely chance of injury to persons unless the relative prescriptions and indications are followed.

The symbol:

CAUTION

marking certain parts of the text indicates the possibility of damaging the pump unless the relative instructions are followed.

EN

SPECIFICATIONS AND TECHNICAL DATA

The first two letters of the pump model code (LW, FW, ZW, etc.) allow identifying the specific model (an exception is represented by the second series of FW pumps, which is indicated by FW2).

		AX	BX	BW	AW	LW	ZW
MECHANICAL CONNECTION							
Max power input ⁽¹⁾	<i>kW</i> <i>CV</i>	0,3÷6,3 0,4÷8,6	0,54÷4,2 0,7÷5,7	2,0÷4,3 2,7÷5,8	4,7÷7,5 6,4÷10,2	0,2÷4,0 0,3÷5,4	3,7÷8,2 5,0÷11,1
Max rotation speed		See following table					
PUMP OIL		AGIP ROTRA MULTI THT ⁽²⁾					
Quantity in weight	<i>kg - lb</i>	0,16 - 0,35	0,10 - 0,22	0,25 - 0,55	0,25 - 0,55	0,28 - 0,62	0,36 - 0,79
Quantity in volume	<i>l - USgal</i>	0,18 - 0,05	0,11 - 0,03	0,28 - 0,07	0,28 - 0,07	0,32 - 0,08	0,41 - 0,11
HYDRAULIC CONNECTION							
Max water temperature ⁽³⁾	<i>°C - °F</i>	60 - 140					
Min water temperature	<i>°C - °F</i>	5 - 41					
Max water pressure	<i>bar - psi</i>	8 - 116					
Max priming depth	<i>m - ft</i>	1 - 3,3 (1000, 1450 and 1750 RPM)		0,5 - 1,7 (2800 and 3400 RPM)			
Min water flow rate		1,3 x max flow rate					
PERFORMANCE - WEIGHT							
Max flow rate		See following table					
Max pressure		See following table					
Max level of sound pressure - uncertainty		79 dB(A) 1 dB(A)					
Max weight	<i>kg - lb</i>	6,0 - 13,2	4,7 - 10,3	6,0 - 13,2	6,5 - 14,3	7,2 - 15,9	7,9 - 17,5

		FW	FW2	HW	RW	SW	TW
MECHANICAL CONNECTION							
Max power input ⁽¹⁾	<i>kW</i> <i>CV</i>	3,7÷7,7 5,0÷10,5	4,0÷10,5 5,4÷14,2	7,1÷11,5 9,7÷15,6	4,4÷11,6 6,0÷15,8	5,5÷7,5 10,8÷14,5	7,5÷20,5 10,2÷27,9
Max rotation speed		See following table					
PUMP OIL							
AGIP ROTRA MULTI THT ⁽²⁾							
Quantity in weight	<i>kg - lb</i>	0,50 - 1,1	0,50 - 1,1	0,50 - 1,1	0,70 - 1,5	0,97 - 2,1	0,97 - 2,1
Quantity in volume	<i>l - USgal</i>	0,56 - 0,15	0,56 - 0,15	0,56 - 0,15	0,79 - 0,21	1,1 - 0,28	1,1 - 0,28
HYDRAULIC CONNECTION							
Max water temperature ⁽³⁾	<i>°C - °F</i>	60 - 140					
Min water temperature	<i>°C - °F</i>	5 - 41					
Max water pressure	<i>bar - psi</i>	8 - 116					
Max priming depth	<i>m - ft</i>	1 - 3,3 (1000, 1450 and 1750 RPM)		0,5 - 1,7 (2800 and 3400 RPM)			
Min water flow rate		1,3 x max flow rate					
PERFORMANCE - WEIGHT							
Max flow rate		See following table					
Max pressure		See following table					
Max level of sound pressure - uncertainty		79 dB(A) 1 dB(A)					
Max weight	<i>kg - lb</i>	9,2 - 20,2	9,2 - 20,2	10,0 - 22,0	11,2 - 24,7	18,0 - 40,0	20,0 - 44,0

Specifications and details are approximate. The Manufacturer reserves the right to make all changes to the appliance deemed necessary.

⁽¹⁾ Depending on specific model.

⁽²⁾ Corresponding oils:

U.T.T.O. (Universal Tractor Transmission Oil)	API GL-4	John Deere J20A
Massey-Ferguson M-1135	Ford M2C - 86 B	Esso Torque Fluid 62
Mobil Mobilfluid 422	Ford M2C - 134 B/C	Shell Donax TD

⁽³⁾ On request, models are available able to operate with water at a temperature of 85 °C/185 °F..

The third letter allows determining the top rotation speed, according to the following table:

Third letter	RPM
N	1000
Absent	1450
S	1750
R	2800
D	3400

For example: TWN 5636 (1000 RPM), LW 2020 (1450 RPM), HWD 4040 (3400 RPM).

A K, preceded by a dash (LW-K, ZW-K), means the pump features a built-in pressure unloader/regulation valve (e.g.: LWR-K 2020, ZW-K 4022). This rule does not apply to the AX and BX models because these already feature built-in pressure unloader/regulation valves.

The model code numbers allow determining max flow rate and pressure.

By means of the first two figures (if the number consists of four figures) or by means of the first three figures (if the number consists of five figures) the max flow rate can be determined according to the following table:

Max flow rate in l/min = first two (or three) figures x 0.378
Max flow rate in USgpm = first two (or three) figures : 10

E.g.: TW 10522 (105 x 0.378 = 39.7 l/min), LW 2015 (20 : 10 = 2 USgpm).

By means of the last two figures, the maximum pressure can be determined according to the following table:

Max pressure in bar = last two figures x 6.9
Max pressure in psi = last two figures x 100

E.g.: TW 10522 (22 x 6.9 = 151.8 bar), LW 2015 (15 x 100 = 1500 psi).

NOTE: in the case of FW2, the “2” must be excluded from what is before which identifies the second series of FW pumps.

IDENTIFICATION OF COMPONENTS

Refer to Figures from 1 to 3 at the beginning of the manual.

- | | |
|---------------------------|-------------------------------|
| 1. Suction fitting | 11. Motor flange support |
| 2. Pump head | 12. Pump shaft |
| 3. Suction valve cap | 13. Oil drain cap |
| 4. Pressure gauge fitting | 14. Detergent suction fitting |
| 5. Delivery fitting | 15. Pressure adjustment knob |
| 6. Delivery valve cap | 16. Detergent adjustment knob |
| 7. Identification plate | 17. Oil cap without vent |
| 8. Oil cap with vent | 18. Pump foot |
| 9. Pump crankcase | 19. Safety valve connector |
| 10. Oil level indicator | 20. Thermal valve connector |

EN

PUMP IDENTIFICATION PLATE



WARNING

- Should the identification plate deteriorate during use, contact the Manufacturer or a **Skilled Technician** to have it restored.

The identification plate (7) shows the serial number and the pump model by means of a specific code which permits identifying the main technical specifications (see “**SPECIFICATIONS AND TECHNICAL DATA**” paragraph). It is located on the pump crankcase.

SAFETY DEVICES



WARNING

- The machine in which the pump is integrated must always feature a pressure unloader/regulation valve.
- If the machine in which the pump is integrated also features a safety valve, i.e., a max. pressure valve, suitably calibrated, which discharges excess pressure in case of a fault in the high-pressure circuit, in the event of the safety valve tripping frequently, immediately stop using the machine in which the pump is integrated and have it checked by a **Skilled Technician**.

Pressure unloader/regulation valve.

Standard on pumps marked with the letter K preceded by a dash and on the AX and BX series pumps. Available as an optional accessory for the other models.

This valve is suitably set by the Manufacturer, allows regulating the operating pressure and permits the pumped fluid to flow back towards the bypass duct, thus preventing the accumulation of dangerous pressures when the delivery line is closed or when attempts are made to set pressure values above the maximum ones allowed.

WARNING

- The pressure unloader/regulation valve is set either by the pump Manufacturer or by that of the machine in which the pump is integrated. **Never try and adjust the pressure unloader/regulation valve to alter its setting; only adjust this by means of the knob (15).**

INTENDED USE

WARNING

- **The pump must not be run by itself. It is only meant to be integrated in a machine.**
- The pump must only be integrated in machines used for the following purposes:
 - pumping of water at high pressure in washing machines (high pressure cleaners);
 - pumping water for non-edible use.
- The pump must not be integrated in machines for pumping:
 - unfiltered water or with impurities;
 - detergents, paints and chemical substances, both pure and in aqueous solution;
 - seawater or water with high salt concentration;
 - fuels and lubricants of all kinds and types;
 - inflammable liquids or liquefied gases;
 - edible liquids;
 - solvents and thinners of all kinds and types;
 - water with temperatures above 60 °C/140 °F or below 5 °C/41 °F;
 - liquids containing granules or solid parts in suspension.
- The pump must not be integrated in machines designed to wash: people, animals, energized electrical apparatus, delicate objects, the pump itself or the machine in which it is integrated.
- The pump is not suitable for being integrated in machines designed to operate in environments with special conditions such as, for example, corrosive or explosive atmospheres.
- For integration in machines designed to operate on board vehicles, ships or planes, contact the Manufacturer's Technical After-Sales Service, inasmuch as additional requirements may be necessary.
All other uses are to be deemed incorrect.
The Manufacturer disclaims all liability for any damage deriving from incorrect or erroneous uses.

PRELIMINARY ACTIVITIES

WARNING

- **The pump cannot be operated unless the machine in which it is integrated conforms to the safety requirements laid down by European directives. Such conformity is indicated by **CE** markings and by the declaration of conformity of the Manufacturer of the machine in which the pump is integrated.**
 - Before starting the pump, carefully read the instructions in this manual and in the manual of the machine in which the pump is integrated. In particular, make sure you have correctly understood how the pump and the machine in which it is integrated work as regards liquid on/off operations.
 - Perform the preliminary operations indicated by the Manufacturer of the machine in which the pump is integrated.
 - Make sure all deliveries are off or connected to accessories that have been turned off (e.g., closed spray gun).
 - Make sure that the moving parts of the pump are suitably protected and that they are not accessible to unauthorised persons.
 - Do not use the pump (and therefore the machine in which it is integrated) in the event of:
 - the safety devices being damaged;
 - its having suffered heavy knocks;
 - evident oil leaks;
 - evident leaks of pumped liquid.
- In such cases, have the pump and the machine in which it is integrated checked by a **Skilled Technician**.
- Have a **Skilled Technician** perform the inspections required by special maintenance.

- Wear clothing and personal protective equipment able to provide adequate protection from any high-pressure jets and chemical products used.

CAUTION

- In case of operation at very low temperatures, make sure there is no ice inside the pump and pipes.
- Perform the checks required by routine maintenance, with special reference to those relating to the oil.

Carry out the preliminary activities indicated in the manual of the machine in which the pump is integrated; unless otherwise indicated, with respect to the pump, always remember the following.

- Replace the oil cap without vent (17) with the oil cap with vent (8) (see Fig. 3). This operation could already have been performed by the Manufacturer of the machine in which the pump is integrated.
- With the pump off and completely cooled down, make sure the oil level is at mid-point of the oil level indicator (10). The oil level can also be checked (except for AX and BX models) by unscrewing the cap with vent (8): the correct level is between the two notches shown on the dipstick.
For any touch ups, refer to the types of lubricants indicated in the paragraph **"SPECIFICATIONS AND TECHNICAL DATA"**.
- Refer to the operation and maintenance manual of the machine in which the pump is integrated and make sure the suction filter is clean.

EN

CHECKING AND CONNECTING UP TO WATER MAINS



WARNING

- Also follow the instructions contained in the manual of the machine in which the pump is integrated.
- Follow the water mains connection instructions applicable in the country where the machine in which the pump is integrated is installed.

CAUTION

- Follow the water mains connection instructions shown in the **"SPECIFICATIONS AND TECHNICAL DATA"** paragraph, with special reference to the priming depth and supply pressure and temperature: in case of any doubts, contact a **Skilled Technician**.
- The suction of pump must always be equipped with a suitably-sized filter: frequently make sure this is clean.
- Never operate the pump:
 - without water supply;
 - with salt water or water containing impurities: if this occurs, have it operate for a few minutes with clean water.

STANDARD OPERATION (HIGH PRESSURE)



WARNING

- Also follow the instructions contained in the manual of the machine in which the pump is integrated with special reference to the parts relating to the safety precautions, any use of personal protective equipment (protective eyewear, ear muffs, etc.) and handling.
- Before starting up the machine in which the pump is integrated, carefully read the machine's manual and this manual. In particular, make sure you have fully understood how the pump and the machine in which it is integrated work as regards liquid on/off operations.
- The pump and the machine in which it is integrated are not intended to be used by people (including children) with reduced physical, sensorial or mental capacities, or who lack the experience and expertise, unless they are able to benefit, through the intermediation of a person responsible for their safety, from supervision or instructions concerning the use of the pump and of the machine in which it is integrated.
- Children must be supervised to make sure they do not play with the pump and with the machine in which it is integrated.
- Special care must be taken when using the pump in environments where there are moving vehicles which could crush or damage any: delivery pipe, spray gun and nozzle.

- Before using the pump, put on individual protective gear and devices to ensure adequate protection from wrong manoeuvres with the jet of fluid under pressure.
- **WARNING.** Do not use the pump or the machine in which it is integrated near people if these are not wearing personal protective equipment.
- **WARNING.** Do not direct high-pressure jets against yourself or other people to clean clothes or footwear.
- **WARNING.** High-pressure jets can be hazardous if incorrectly used. High-pressure jets must not be directed against people, energized electrical appliances or the pump itself or the machine in which it is integrated.
- Never run the machine in which the pump is integrated in closed premises, if this is driven by an internal combustion engine.
- **WARNING.** Explosion risk - Do not spray inflammable liquids.
- Read the **"OPERATION WITH DETERGENT"** paragraph carefully.
- Keep clear of moving parts of the pump and of the machine in which it is integrated, even if these are adequately protected.
- Do not remove the guards of the moving parts.
- Do not touch pipes containing liquids under pressure.
- Do not perform maintenance operations on the pump and on the machine in which it is integrated if this is operating.
- Read the **"INTENDED USE"** paragraph carefully.
- Do not modify in any way the installation conditions of the pump. In particular, do not modify the fastening, the hydraulic connections and the guards.
- Do not open any taps on the pump unless these are connected to an accessory that prevents the accidental escape of the pumped liquid.
- Do not deactivate or tamper with the controls and the safety devices and the pressure unloader/regulation valve.
- The connection of the machine in which the pump is integrated to the power mains must be made by a Professional Electrician in accordance with the regulations applicable in the country of use.

During operation:

- always keep an eye on the pump and the machine in which it is integrated and out of the reach of children; in particular, be very careful when using near nurseries, clinics and old-people's homes, in case of children, elderly people or disabled people without supervision;
- do not direct high-pressure jets against materials containing asbestos or other substances harmful for the health;
- do not cover the pump and the machine in which it is integrated and do not place them where ventilation is prevented (remember this above all when using the machine in closed environments);
- grip any spray gun tightly because when the lever is operated a reaction force of the high-pressure jet is produced;
- when not in operation and before doing any jobs, perform the operations described in the **"STOP"** paragraph;
- operating pressure must never exceed the maximum value set for the pump (see also **"SPECIFICATIONS AND TECHNICAL DATA"** paragraph);
- use adequate personal protective equipment to safeguard against noise emissions (e.g., ear muffs).

Perform the steps relating to the high-pressure operation indicated in the manual relating to the machine in which the pump is integrated; unless otherwise indicated, in relation to the pump, the following should be remembered.

- To allow pump priming, reset the delivery pressure, and open one of the accessories. In the case of a high-pressure cleaner, for example, simply keep the spray gun lever pressed.
- Start the pump.
- If the possibility exists of adjusting the delivery pressure, set the required pressure. In the case of models with built-in regulation valve (pumps marked by K preceded by a dash and series AX and BX), pressure adjustment can be achieved by means of the knob (15): when this is turned clockwise, pressure increases, when turned anticlockwise, pressure is reduced.

 **WARNING**

- Never touch the pressure unloader/regulation valve so as not to alter its setting; only adjust this valve by means of the knob (15).

CAUTION

- To permit fast pump priming, proceed as indicated at point a) every time the pump has to be primed again.
- During the first hours of operation, it is best to check the oil level and, if necessary, top up the level, following the instructions in the **"PRELIMINARY ACTIVITIES"** paragraph.
- In the case of models with built-in regulation valve (pumps marked by K preceded by a dash and series AX and BX) and of all those applications where the pressure unloader/regulation valve bypass is connected to pump suction, do not keep the delivery line closed for more than five minutes (e.g., with spray gun closed), so as to prevent the water recirculating in the head from overheating with consequent seal damage.
- Do not operate the pump if it is too noisy and/or water or oil is dripping from it: in this case have it checked by a **Skilled Technician**.

OPERATION WITH DETERGENT

EN

WARNING

- **Follow the instructions contained in the manual of the machine in which the pump is integrated.**
- *The pump has been designed to be used with the detergents recommended by the Manufacturer. The use of different detergents or chemical products could cause safety problems. In particular, never suck up liquids containing solvents, petrol, thinners, acetone and fuel oils, because the nebulized product is highly inflammable, explosive and toxic.*
- *Carefully read the instructions and safety precautions on the detergent packs, so as to be able to implement the necessary measures in case of hazards threatening individuals and the environment. In particular, never exceed the maximum recommended concentrations and only prepare the quantity of product needed to prevent it spreading on the ground and in waters.*
- *Store the detergents in a safe place out of reach of children.*
- *In case of contact with the eyes, wash immediately with water. In case of ingestion, do not provoke vomiting: immediately contact a doctor and show him/her the detergent pack. Avoid inhaling any produced gases.*

The detergent suction option is standard only for a number of models of the LW, ZW, AX and BX series.

To learn how to use the detergent, refer to the detergent pack label, with special attention to doses.

Perform the steps relating to operation with detergent shown in the manual of the machine integrating the pump; unless otherwise indicated, in relation to the pump, the following should be remembered.

- a) Reduce the pressure of the pump to below 30 bar/435 psi (e.g., in the case of a high pressure cleaner, by moving the nozzle head to low-pressure position).
- b) If the detergent suction adjustment option is provided, adjust the knob (16): turn it clockwise to reduce the flow of detergent suctioned and anticlockwise to increase such flow.

CAUTION

- To prevent scale and/or deposits, after using with detergent, it is best to wash the flow ducts by sucking up some water.

STOPPING OPERATION

By closing the delivery line, the pump switches to bypass operation and remains in this condition until the delivery line is opened again.

CAUTION

- Never leave the pump in bypass for more than five minutes, and avoid the water re-circulating in the pump head from overheating, with consequent damage to seals.

STOPPING, CLEANING AND DECOMMISSIONING

WARNING

- Follow the instructions regarding stopping, cleaning and decommissioning contained in the manual of the machine in which the pump is integrated.

STOPPING

WARNING

- Always make sure that, once stop operations have been performed, no part of the pump and of the machine in which it is integrated is moving and no pipes contain liquid under pressure.
Always remember in particular, if present:
 - to disconnect the power supply;
 - to disconnect the sparking plug contact (petrol motors), or remove the ignition key (diesel engines).

Perform the stop operations contained in the manual of the machine in which the pump is integrated; unless otherwise indicated, in relation to the pump, remember the following.

- a) Close the water supply.
- b) Stop the machine in which the pump is integrated.
- c) Reset the delivery pressure as described at a) of the “**STANDARD OPERATION (HIGH PRESSURE)**” paragraph.
- d) Wait for the pump and the machine in which it is integrated to cool down.

WARNING

- Once the pump and the machine in which it is integrated have cooled down, be careful:
 - not to leave them unattended in the presence of children, elderly people or disabled persons without supervision;
 - to arrange them in a stable position without any risk of falling;
 - not to put them in contact or in the immediate vicinity of inflammable materials.

CLEANING AND DECOMMISSIONING

WARNING

- **WARNING.** All cleaning jobs must only be performed after carrying out the operations described in the “**STOP**” paragraph, meaning **without any moving parts, no pipe full of liquid under pressure and only after complete cooling.**
In particular, always remember to disconnect the power supply.
- Any cleaning jobs must be performed in conditions of total stability.
- To clean, do not use thinners or solvents.

CAUTION

- Refer to the manual of the machine in which the pump is integrated and after use, always empty out all the pumped liquid.
- **The pump must be protected against freezing.**
In very cold environments, to prevent the ice from forming inside, before decommissioning, it is best to suction a car anti-freeze product (after contacting a Skilled Technician inasmuch as the liquid could damage the high-pressure pump seals) and then proceed to fully expel it. If it is not possible to protect the pump this way, before starting it, take it to a warm environment for long enough to melt any ice inside. Failure to do so could cause serious damage to the pump.

WARNING

- The antifreeze liquid must be suitably disposed of and not discarded in the environment.

NOTE: After a prolonged stop, slight water dripping could occur underneath the pump. Such dripping normally disappears after a few hours of operation. Should it persist, contact a **Skilled Technician**.

MAINTENANCE

WARNING

- Follow the maintenance instructions contained in the manual of the machine in which the pump is integrated.
- All maintenance jobs must only be performed after carrying out the operations described in the **"STOP"** paragraph, meaning **without any moving parts, no pipe full of liquid under pressure and only after complete cooling**.
In particular, always remember to disconnect the power supply.
- Any maintenance jobs must be performed in conditions of total stability.
- **WARNING.** To ensure the safety of the pump, only use original spare parts supplied by the Manufacturer or approved by it.

EN

ROUTINE MAINTENANCE

Perform the routine maintenance jobs shown in the manual of the machine in which the pump is integrated; unless otherwise indicated, in relation to the pump, remember the following.

MAINTENANCE SCHEDULE	JOB
After every use	• Check oil level and conditions according to instructions in "PRELIMINARY ACTIVITIES" paragraph.
Every 50 hours	• Check the integrity of the suction circuit. • Check and if necessary clean the suction filter. • Check the fastening of the pump to the motor to which it is coupled and/or to the structure of the machine in which it is integrated. In the event of such fastening being precarious, do not use the machine and contact a Skilled Technician ⁽¹⁾ .

⁽¹⁾ Checks must be made more frequently if the pump operates where there are strong vibrations.

SPECIAL MAINTENANCE

WARNING

- Special maintenance jobs must only be performed by a **Skilled Technician**.
- Used oil must be adequately disposed of and not discarded in the environment.

Perform the routine maintenance jobs shown in the manual of the machine in which the pump is integrated; unless otherwise indicated, in relation to the pump, remember the following.

MAINTENANCE SCHEDULE	JOB
Every 500 hours (200 hours for series AX and BX).	• Check the suction/delivery valves. • Check the tightness of the pump screws ^(*) . • Oil change ^(**) . • Check the pressure unloader/regulation valve.

^(*) Checks should be made more frequently if the pump operates where there are strong vibrations.

^(**) The first oil change is best made after 50 hours.

CAUTION

- The data shown on the chart are approximate. More frequent jobs may be necessary in case of particularly heavy-duty use.

DISMANTLING AND DISPOSAL

Only qualified persons must be allowed to dismantle the pump and this operation must be performed in compliance with the laws applicable in the country where the machine in which it is integrated has been installed.

TROUBLESHOOTING

WARNING

- *Also follow the instructions contained in the manual of the machine in which the pump is integrated.*
 - *Before doing any jobs, perform the operations described in the "STOP" paragraph.*
- In the event of not being able to restore the correct operation of the pump with the aid of the information contained on the following table, contact a **Skilled Technician**.*

PROBLEMS	CAUSES	REMEDIES
The pump does not prime.	Suction of air. Delivery line closed (e.g., spray gun closed). Suction circuit with choke points.	Check the integrity of the suction circuit. Reset the delivery pressure (e.g., press the spray gun lever). Check the suction circuit (especially make sure the suction filter is clean).
The pump fails to reach max pressure.	Pressure adjustment knob (15) not tightened enough. Not enough water supply or priming too deep. Suction circuit with choke points. Unsuitable conditions of use (e.g., nozzle worn, lance in low-pressure position, etc.)	Turn the knob clockwise until required pressure is achieved. Make sure the water supply flow rate or priming depth is in compliance with the indications in the " SPECIFICATIONS AND TECHNICAL DATA " paragraph. Check the suction circuit (especially make sure the suction filter is clean). Restore the correct conditions of use.
Irregular pressure and flow rate (pulsating).	Air suction. Suction filter dirty. Not enough water supply or priming too deep. The pump has not completed priming. Accessory clogged (e.g. clogged nozzle).	Check the integrity of the suction circuit. Clean the filter. Make sure the water supply flow rate or priming depth is in compliance with the indications in the " SPECIFICATIONS AND TECHNICAL DATA " paragraph. Prime the pump according to the indications of the " STANDARD OPERATION (HIGH PRESSURE) " paragraph. Restore the correct use of the accessory.
Too much noise.	Suction circuit with choke points. Water supply temperature too high.	Check the suction circuit (especially make sure the suction filter is clean). Keep to the temperatures indicated in the " SPECIFICATIONS AND TECHNICAL DATA " paragraph.
Low detergent suction.	Use of the accessory not in low-pressure mode (e.g., lance not in low-pressure position). Detergent metering device closed or set for low suction. Use of detergent which is too viscous.	Restore the correct use of the accessory. Turn the detergent adjustment knob (16) anticlockwise. Keep to uses and dilutions shown on detergent plate.

PART TWO

(for Skilled Technicians only)

WARNING

- This part of the manual is dedicated to **Skilled Technicians** and is not intended for users of the machine in which the pump is integrated.

UNPACKING

WARNING

- During unpacking, always wear gloves and protective eyewear, to prevent injuring hands and eyes.
- Some pumps are heavy components (also refer to the “**SPECIFICATIONS AND TECHNICAL DATA**” paragraph) and these are therefore best unpacked by cutting away the bottom of the cardboard box.
- The packaging elements (plastic bags, staples, etc.) must not be left within reach of children as they represent potential hazard sources.
- Packaging components must be disposed of according to the regulations in force in the country where the machine in which the pump is integrated has been manufactured.
Plastic packaging must not be discarded in the environment.
- After unpacking the pump, make sure no parts are missing and that all parts are in perfect condition, and that the identification plate is in place and legible.
In case of any doubt, do not install the pump, but contact the Manufacturer or a **Skilled Technician**.
- This manual and the warranty certificate must always accompany the machine in which the pump is integrated and made available to the end user.

EN

STANDARD FITTINGS

Make sure the purchased product consists of the following elements:

- pump;
- oil cap with vent (8);
- pump manual;
- declaration of incorporation;
- warranty certificate.

In case of problems, contact the Manufacturer or a **Skilled Technician**.

INSTALLATION

WARNING

- The **Skilled Technician** must abide by the installation instructions contained in this manual, in particular, the specifications of the motor (electric or internal combustion), to be coupled to the pump must be in conformity with the constructive performance and specifications of the pump (power, rotation speed, flanging, etc.), as shown on the Manufacturer's technical documentation.
- **The machine in which the pump is integrated must be made in such a way as to ensure conformity with the safety requirements indicated in the European Directives. This fact is guaranteed by CE markings and by the Declaration of Conformity of the Manufacturer of the machine in which the pump is integrated.**
- The pump must be installed and allowed to operate horizontally (for any exceptions in merit, contact the Manufacturer).
- The pump must be stably fastened.
- Being of the positive-displacement type, the pump must always be equipped with a pressure unloader/regulation valve (such valve is already built in the pump marked by the letter K preceded by a dash and in the AX and BX series pumps).

OPTIONAL ACCESSORIES

WARNING

- *Inadequate optional accessories could negatively affect pump operation and make this hazardous. Only ever use original optional accessories recommended by the Manufacturer.*
- *As regards general information, safety precautions, installation and maintenance of optional accessories, refer to the accompanying documents.*

The standard pump equipment can be integrated with the following range of accessories:

- pressure unloader/regulation valve;
- safety valve;
- thermal valve;
- suction filter;
- suction fitting of various shapes and sizes;
- pressure gauge;
- etc.

For further details contact your dealer.

APPLICATIONS

WARNING

- *Adequately protect the moving parts with suitable guards. Special attention must be given to pulley applications.*
- *The pump must operate without exceeding the pressure limits and rotation speed as shown on the plate (7) (also refer to the **"SPECIFICATIONS AND TECHNICAL DATA"** paragraph). In particular, always make sure the pressure unloader/regulation valve is correctly set and that this setting is guaranteed, e.g., by paint coating.*
- *The pump must always be firmly fastened either to the motor flange or on a stable base by means of the feet (optional).*

The pumps described in this manual, depending on the model, are available in versions for numerous applications:

- female shaft Ø 3/4" for internal combustion engine with flange SAE J 609 A;
- female shaft Ø 1" for internal combustion engine with flange SAE J 609 A;
- female shaft Ø 5/8" for electric motor NEMA 56 C;
- female shaft Ø 24 mm for electric motor MEC size 90 B3 - B14;
- male shaft Ø 24 mm for special electric motor with female shaft or for pulley;
- female shaft Ø 20 mm for internal combustion engine with gear reduction unit;
- female shaft Ø 28 mm for electric motor MEC size 100-112 B3 - B14;
- female shaft Ø 1"1/8 for electric motor NEMA 182-184 TC;
- female shaft Ø 25 mm for internal combustion engine with gear reduction unit;
- male shaft Ø 30 mm for special electric motor with female shaft or for pulley or for gear reduction unit or for flexible coupling.

The Manufacturer's After-Sales Service is at the disposal of the **Skilled Technician** to provide all necessary information to identify the most adequate application and its correct execution. Pump applications must in any case be executed according to proper rules of mechanical engineering.

The pump is able to turn both clockwise and anticlockwise.

HYDRAULIC CONNECTION

For the hydraulic suction, delivery and bypass connections, refer to the following table and to Fig. 4, which represents a generic diagram of a possible machine integrating the pump.

- A Pump**
- B Pressure unloader /regulation valve**
- C Suction circuit**
- D Delivery circuit**
- E Spray gun (example of accessory)**
- F Motor**
- G Lance**
- H Nozzle head**

EN

CAUTION

- Follow the connection instructions already indicated in the **“CHECKING AND CONNECTING UP TO THE WATER SUPPLY”** and **“SPECIFICATIONS AND TECHNICAL DATA”** paragraphs.
In particular, the suction circuit must be sized so as not to determine on the pump suction fitting:
 - a pressure higher than 8 bar/116 psi;
 - a vacuum higher than: 0,15 bar/2,18 psi (series AX, BX and pumps at 1000, 1450 and 1750 RPM); 0,1 bar/1,45 psi (MTP LWR-K, MTP ZWR-K); 0,1 bar/1,45 psi (pumps at 2800 and 3400 RPM).
- At pump suction, a filter of adequate dimensions must be fitted. In case of doubts, contact the Manufacturer.
- The suction pipes must have a suitable internal diameter and a nominal pressure of 10 bar/145 psi.
- The delivery pipes must have a nominal pressure not below the pump max. pressure.

On the models LW, ZW, FW, RW, HW, AW, BW, SW and TW, suction and delivery fittings are available both on the right side and on the left side of the head.

PRESSURE UNLOADER/REGULATION VALVE

In the models in which it is already built-in (pumps marked with the letter K preceded by a dash and pumps of the AX and BX series), this is factory set so maximum pump pressure is achieved, using a nozzle which also allows having a small flow rate in bypass (at least 0.3-0.6 l/min/0.08-0.16 USgpm).

The Manufacturer's Technical Assistance Service is at the disposal of the **Skilled Technician** to provide all the information needed, taking into account the fact that such adjustment may have to be corrected according to the plant engineering configuration in which the pump is installed.

RESETTING THE PRESSURE UNLOADER/REGULATION VALVE

WARNING

- *Operating pressure must never exceed the maximum value indicated for the pump (see also the **“SPECIFICATIONS AND TECHNICAL DATA”** paragraph).*

To reset the valve, proceed as follows (refer to Fig. 5):

- remove the plastic knob by pulling it upwards;
- loosen the Allen screw (m);
- turn the retention ring nut (l) anticlockwise, so as to partially unscrew it;
- set the required pressure by means of the hexagonal knob (n) (turn clockwise to increase the pressure, anticlockwise to reduce the pressure);
- turn the retention ring nut (l) clockwise, to tighten it;
- fully tighten the Allen screw (m).

SPECIAL MAINTENANCE

Follow the instructions in the corresponding paragraph of section one.

The tightening torques to be used are shown on the following table (refer to Fig. 5).

		Tightening torques Nm (lb.ft)						
	Description	AX	BX	BW	AW	LW ZW	FW	Adhesive to be applied
a	Head screws	25 (18,4)	25 (18,4)	10 (7,4)	< 230bar 10 (7,4)	10 (7,4)	25 (18,4)	
					> 230bar 80 (59,0)			
	Valve caps (aluminium head)	35 (25,8)				40 (9,5)		Loctite 243
b	Valve caps (brass head)	45 (33,2)	45 (33,2)	45 (33,2)	45 (33,2)	< 230bar 50 (36,9)	50 (36,9)	Loctite 243
						> 230bar 60 (44,3)		Loctite 243
c	Cover screws			4 (3,0)	4 (3,0)	4 (3,0)	9 (6,6)	
e	Crankcase cover screws			9 (6,6)	9 (6,6)	9 (6,6)	4 (3,0)	
f	PTO flange screws			9 (6,6)	9 (6,6)	9 (6,6)	25 (18,4)	
g	Plunger nuts			6 (4,4)	6 (4,4)	6 (4,4)	10 (7,4)	Loctite 243
h	Eccentric shaft screw	25 (18,4)						Loctite 243
i	Crankcase screws	25 (18,4)	25 (18,4)					

		Tightening torques Nm (lb.ft)					
	Description	FW 2	HW	RW	SW	TW	Adhesive to be applied
a	Head screws	25 (18,4)	25 (18,4)	25 (18,4)	45 (33,2)	45 (33,2)	
b	Valve caps (brass head)	< 230bar 50 (36,9)	80 (59,0)	< 230bar 50 (36,9)	80 (59,0)		Loctite 243
		> 230bar 80 (59,0)		> 230bar 80 (59,0)		< 360bar 80 (59,0)	Loctite 243
						> 360bar 80 (59,0)	Loctite 270
c	Cover screws	9 (6,6)	9 (6,6)	9 (6,6)	25 (18,4)	25 (18,4)	
d	Connecting-rod screws					25 (18,4)	Loctite 243
e	Crankcase cover screws	4 (3,0)	4 (3,0)	4 (3,0)	9 (6,6)	9 (6,6)	
f	PTO flange screws	25 (18,4)	25 (18,4)	25 (18,4)	25 (18,4)	25 (18,4)	
g	Plunger nuts	10 (7,4)	10 (7,4)	10 (7,4)	15 (11,1)	15 (11,1)	Loctite 243

COMET PLUNGER PUMP SERVICE MANUAL INDEX

1. SAFETY INSTRUCTIONS, OPERATING PROCEDURES AND LIMITS	1
1.1 Installation and Start-up Information	
2. TORQUE SETTING CHART	1-2
2.1 AXD Series Pump	
2.2 LW/ZW Series Pump	
2.3 FW/HW Series Pump	
3. TROUBLE SHOOTING GUIDE	2
4. MAINTENANCE SCHEDULE	3
5. SPECIFICATIONS AND TECHNICAL DATA	3
5.1 Pump Identification	
5.2 Component Identification	
5.3 Technical Data and Performance	
6. PUMP SERVICE GUIDE	
6.1 AXD Series Pump.....	4-7
a. Valve Maintenance	
b. Removing and Replacing Manifold	
c. Seal & V-Packing Maintenance	
d. Seal & V-Packing Reassembly	
e. Plunger Maintenance	
f. Plunger Reassembly	
g. Crankcase Maintenance	
h. Crankcase Reassembly	
i. Unloader Maintenance	
6.2 LW/ZW Series Pump.....	8-11
a. Valve Maintenance	
b. Removing and Replacing Manifold	
c. Seal & V-Packing Maintenance	
d. Seal & V-Packing Reassembly	
e. Plunger Maintenance	
f. Plunger Reassembly	
g. Crankcase Maintenance	
h. Crankcase Reassembly	
6.3 FW/HW Series Pump.....	12-14
a. Valve Maintenance	
b. Removing & Replacing Manifold	
c. Seal & V-Packing Maintenance	
d. Seal & V-Packing Reassembly	
e. Plunger Maintenance	
f. Plunger Reassembly	
g. Crankcase Maintenance	
h. Crankcase Reassembly	
7. PUMP LIMITED WARRANTY.....	15

1. SAFETY INSTRUCTIONS, OPERATING PROCEDURES AND LIMITS

1.1 Start-up Information

- a. **LUBRICATION:** Make sure crankcase is filled with Comet Pump oil. Running this pump without oil will cause damage and void any warranties. Change the pump oil after the initial 50 hours of operation. Change oil every 500 hours after the initial oil change. The oil level of the pump can be checked by removing the oil cap and inspecting the dip stick. The correct level should fall between the min and max lines on the dip stick.
- b. **WET END:** The Comet Pump should never be run dry. Running the pump dry will cause premature wear on the seals, packing and plungers. Running the pump dry for a prolonged period of time may cause damage that cannot be repaired. Do not start a pump with frozen water in the manifold.
- c. **STORAGE:** If there is a risk of freezing, run antifreeze through the pump. Empty any extra liquid inside the pump by running the pump without water for no more than 20 seconds.

2. TORQUE SETTING CHARTS

2.1 AXD Series Pump

POSITION#	TORQUE SETTING	FLUID TO BE USED
1	18 FT/LB	
2	33 FT/LB	LOCTITE 243
3	18 FT/LB	
4	18 FT/LB	LOCTITE 243

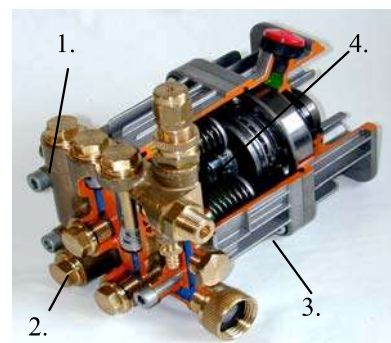

2.2 LW/ZW Series Pump

POSITION#	TORQUE SETTING	FLUID TO BE USED
1	7.5 FT/LB	
2	37 FT/LB	LOCTITE 542
3	4.5 FT/LB	LOCTITE 542
4	6.5 FT/LB	
5	6.5 FT/LB	
6	5.5 FT/LB	

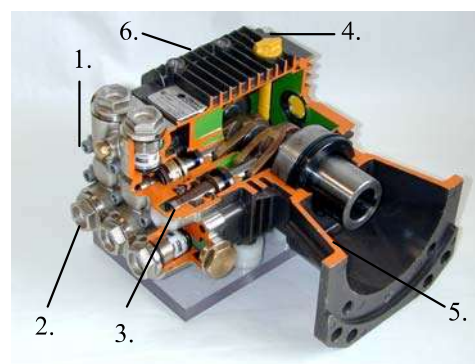

2.3 FW/HW Series Pump

POSITION#	TORQUE SETTING	FLUID TO BE USED
1	18 FT/LB	
2	37 FT/LB	LOCTITE 542
3	7 FT/LB	LOCTITE 542
4	3 FT/LB	
5	18 FT/LB	
6	6 FT/LB	

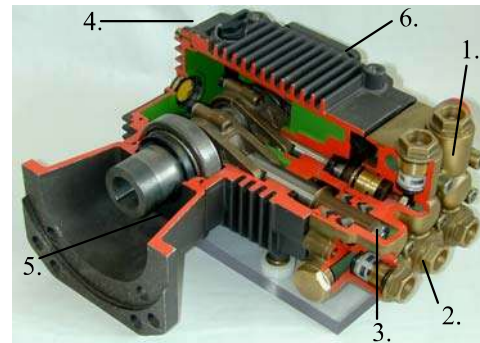

3. TROUBLE SHOOTING GUIDE

SYMPTOMS	CAUSES	REMEDIES
The pump does not start	Air suction	Control inlet device
	Closed lance	Open the lance
Irregular pressure vibration	Pump sucking air	Check that there is no water leaking as it enters the pump
	Nozzle inadequate or worn	Clean and/or replace nozzle
	Worn, dirty/blocked valves	Replace check valves
Irregular pump pressure	Pump sucking air	Check that there is no water leaking as it enters the pump
	Blocked nozzle	Clean and/or replace nozzle
	Air in pump	Pull the trigger to release air in system
	Water inlet filter blocked	Clean filter
	Inadequate water supply	Make sure tap is completely open and/or connect to a tap that has adequate flow rate
	Worn, dirty/blocked valves	Replace check valve
Drop in pressure	Worn nozzle	Install new seal kit
	Dirty or blocked valves	Replace the nozzle
	Worn packing	Replace check valves
Excessive noise	Pump sucking air	Install new seal kit
	Blocked suction	Check that there is no water leaking as it enters the pump
	Water temperature is too hot	Inspect filter and inlet supply
	Worn, dirty/blocked valves	Max water temp must not exceed 145° F
	Worn bearings	Replace check valves
Water leak from head	Worn packing	Replace bearing
Oil leak	Oil seals worn	Install new seal kit
		Install new oil seals

4. MAINTENANCE SCHEDULE

OPERATION	Every 8 hours	Every 50 hours	Every 500 hours
Check oil level	X		
Check tubes-fittings		X	
Check & clean inlet filter		X	
Control pump connection to the engine		X	
Change oil		X –FIRST CHANGE	X
Check suction/delivery valves			X
Check pump bolt and nut setting			X
Check regulation valve			X

5. PUMP SPECIFICATION AND TECHNICAL DATA

5.1 Pump Identification Model#

	Positions:	1.	2.	3.	4.	5.
a.	Model#: eg.	AX	D	30	20	G
POSITIONS:	1. Model:	AX:	radial axial			
		LW:	small frame			
		ZW:	medium duty			
		FW:	heavy duty			
		HW:	super duty			
	2. RPM	D:	3400 RPM			
		S:	1750 RPM			
		-:	1450 RPM			
	3. GPM eg.55:		5.5 GPM			
	4. PSI eg. 30:		3000 PSI			
	5. Flange:	G:	Gasoline engine mounting flange ¾" or 1"			
		E:	Electric Motor Mounting Flange 5/8" or 1 1/8"			
		S:	Solid Shaft 24mm			

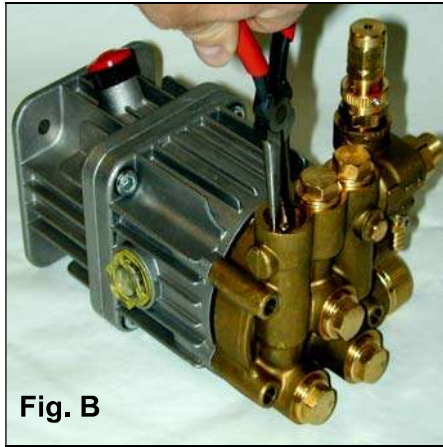
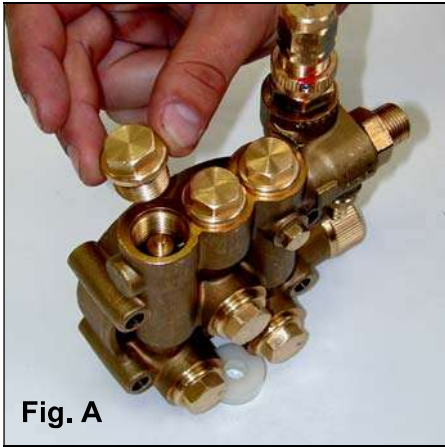

6. PUMP SERVICE GUIDE

6.1. AXD Series Pump

A. Valve Maintenance

1. Using a 17mm wrench, remove the six valve caps on manifold of pump. **(Fig. A)**
2. Examine the valve cap o'ring for cuts or distortions. Replace if worn.
3. Using a needle nose pliers, remove the riser tube and/or suction and delivery check valve. **(Fig B)** The valve assembly usually stays together when removing. If the valve comes apart, use a needle nose pliers or a reverse pliers. Remove the o'ring and replace if worn or damaged.
4. Inspect the suction and delivery check valve assembly for general wear and replace if necessary. The valve assembly consists of the plastic cage, spring, valve seat, poppet and o'ring. **(Fig. C)** One Comet valve kit is needed for a complete valve change in one pump.
5. Replace old valves by placing assembly in the valve chamber. Replace riser tube on top of the check valve where necessary.

Press down firmly on the top of valve assembly or riser tube with your finger. **(Fig. D)**

6. Replace valve caps by applying LOCTITE 243 to valve cap and torque to 33 ft. lbs.

B. Removing & Replacing Pump Manifold

1. Using a 6mm allen head wrench, remove the four head bolts. **(Fig. E)**
2. With the pump firmly secured, take two medium sized flat head screwdrivers and apply pressure to the manifold by prying between crankcase and manifold. **(Fig. F)** Work around from all sides of the manifold evenly until it comes off of the pistons. Keep manifold properly aligned with the crankcase to prevent damage to the seals and pistons.
3. When replacing the manifold, lubricate the pistons and cylinders with grease. Evenly press the manifold toward crankcase until flush.

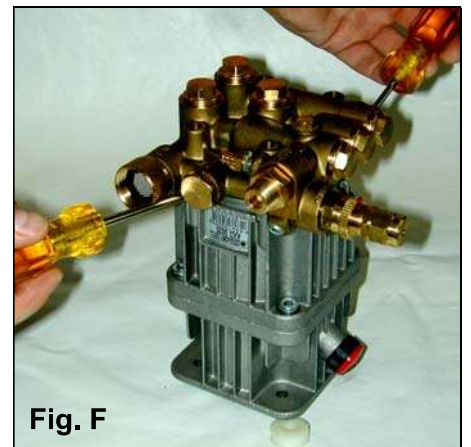
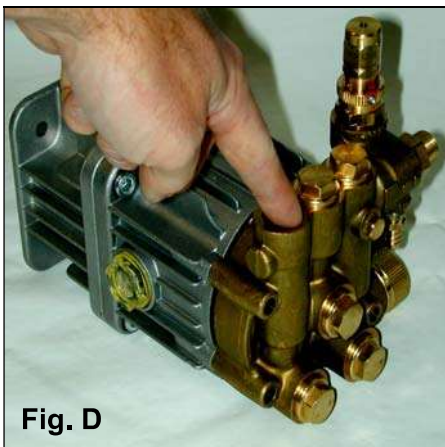

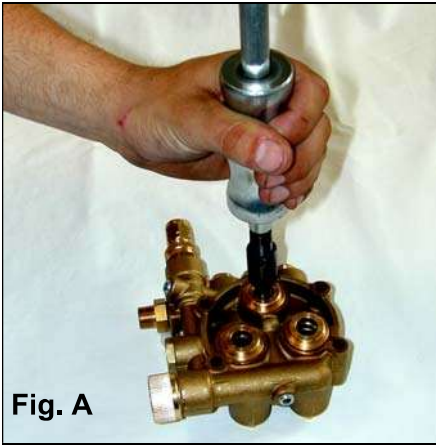

Fig. A

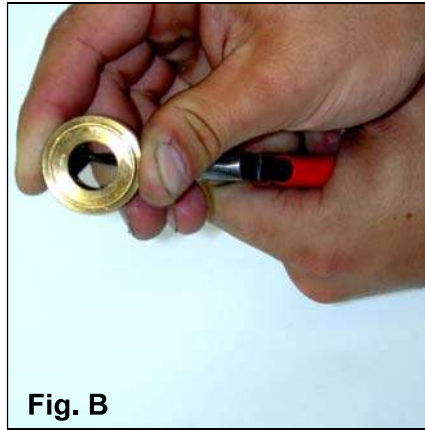

Fig. B

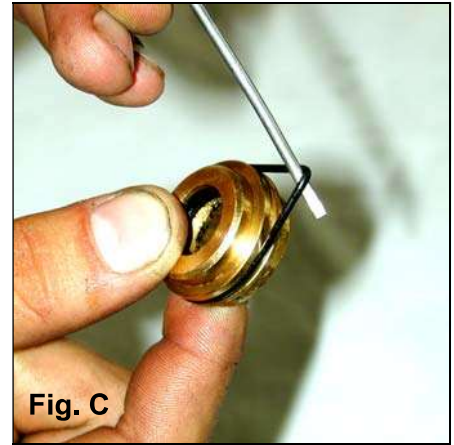

Fig. C

C. Seals and V-Packing Maintenance

1. Remove the manifold as described in section 6.1-B. It is possible that the seal and brass retainer ring assembly stays on the piston or remains in the manifold when removing.
2. Using the packing extraction tool & slide hammer, remove the brass retainer ring/seal stack. **(Fig. A)** Remove the low-pressure seal using a needle nose pliers. **(Fig. B)** Once this seal is removed, replace with a new seal.
3. Remove the outer o’ring by taking a small flat head screwdriver and working your way under the o’ring and simply roll off. **(Fig. C)**
4. The V-packing stack can be taken apart by hand.

2. Insert low-pressure seal using Comet repair tools. **(Fig. D)** Place the brass retainer ring on stand **(Fig. D-1)**. Place tapered stainless steel cylinder **(Fig. D-2)** on top of brass retainer ring with the tapered narrow end on the brass retainer. Insert a new low-pressure seal, closed side facing up, on top of tapered stainless steel cylinder so it lays flat across the top. **(Fig. E)** Gently push the seal down through the tapered cylinder using plastic insertion tool **(Fig. D-3.)** Switch to smaller diameter plastic insertion tool **(Fig. D-4)** to push the seal into its seat inside the brass retainer ring. **(Fig. F)**
3. Replace the outer o’ring by simply starting on one side and working it into the groove.
4. Stack the V-packing in correct order and firmly press assembly into the manifold.
5. Install a new oil seal by laying the seal into the opening and evenly pressing it into place.
6. Reinstall the manifold onto the pump as described in section 6.1-B.

D. Seals and V-Packing Reassembly

1. Generously lubricate the parts when reassembling. Examine brass components for any damage or water residue build-up.

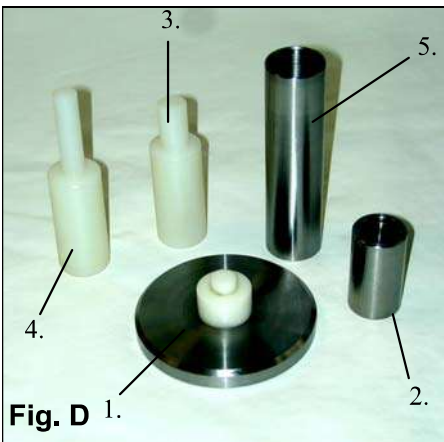

Fig. D

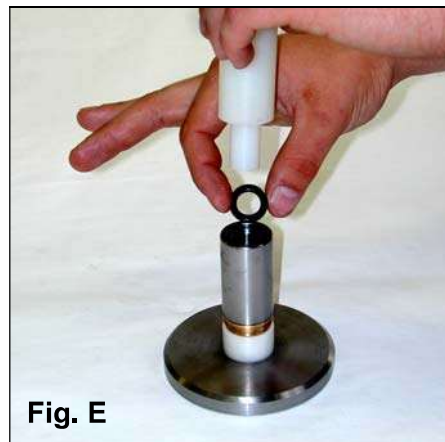

Fig. E

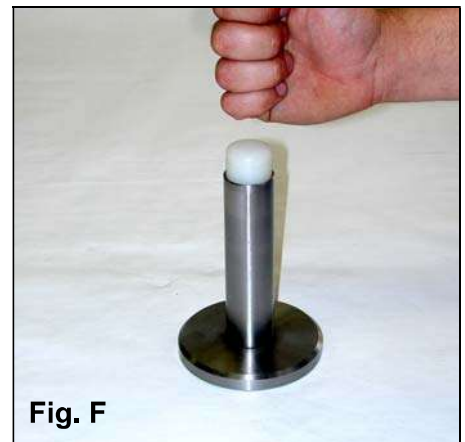

Fig. F

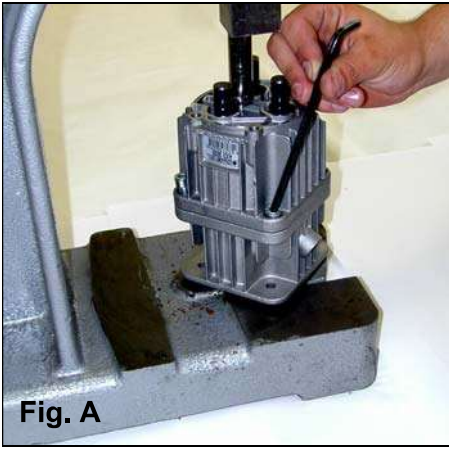

Fig. A

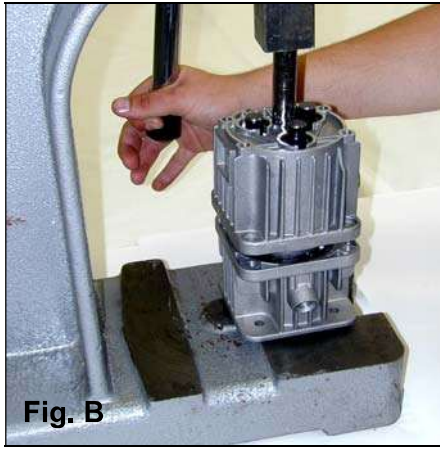

Fig. B

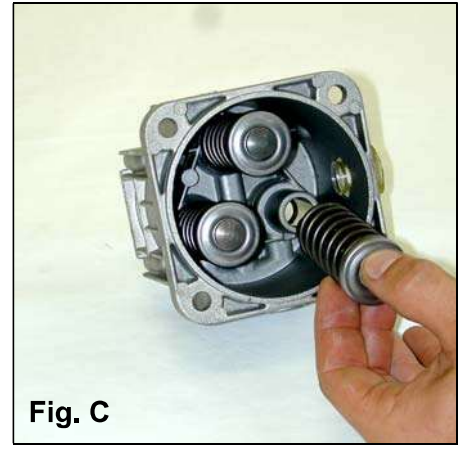

Fig. C

E. Plunger Maintenance

1. Remove the manifold as described in section 6.1-B.
2. Remove the 6mm allen bolts securing the two halves of the crankcase. **(Fig. A)** There are piston return springs energized within the crankcase. When removing the bolts, the two halves of the pump must be held together with a press or something equivalent to keep from springing apart.
3. Once all four bolts are removed, the pump will want to spring apart due to the pressure from the springs. **(Fig. B)**
4. Remove the pistons by pulling down from the inside of the crankcase with your hand. **(Fig. C)**

5. To service the oil seal, take a small flat head screwdriver and apply pressure at a slight side and downward angle. **(Fig. D)** One side of the seal will pop up and can be easily removed.
6. Inspect ceramic piston & all parts for wear. Replace if worn. **(Fig. E)**

F. Plunger Reassembly

1. Slide the piston assembly through the crankcase piston holes. **(Fig. C)** Be certain not to damage or displace the oil seal during this process.
2. With pistons, springs & rings in place, take the two halves of the pump crankcase and press together aligning the four bolt holes. Secure the two halves with the four 6mm allen bolts. **(Fig. B)**

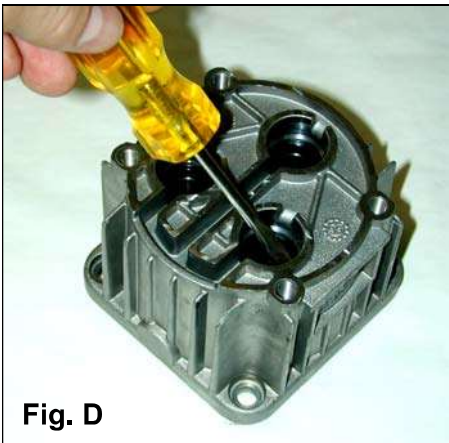

Fig. D

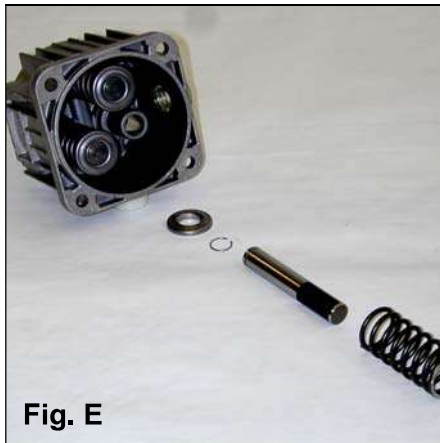

Fig. E

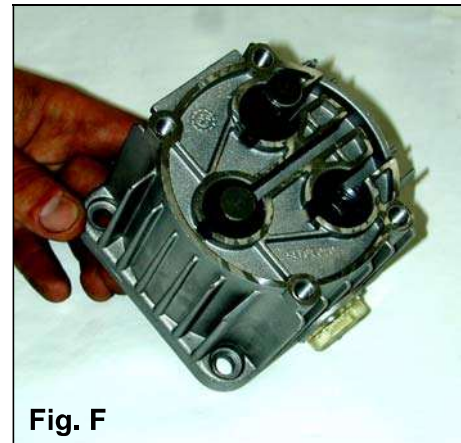

Fig. F

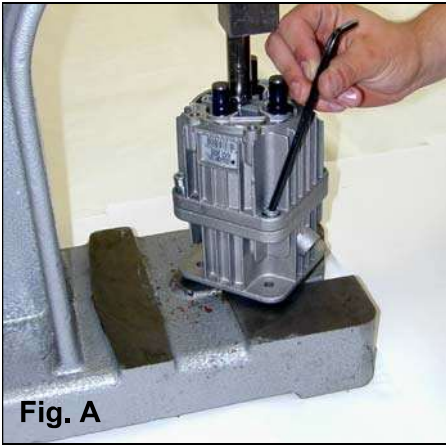

Fig. A



Fig. B

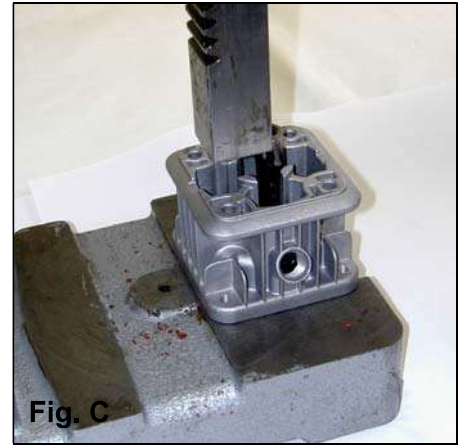

Fig. C

G. Crankcase Maintenance

1. Unscrew the four hex bolts and take the two halves apart as shown in section 6.1-D. There are internal springs pushing these two sections apart. Place the pump in a press, or something equivalent, to keep the two halves from springing apart when the bolts are removed. **(Fig. A)**
2. Once the crankcase is apart, the shaft and bearings are exposed. The components fit on top of each other in order according to the parts breakdown manual. **(Fig. B)**
3. Remove thrust bearing, axial bearing by hand.
4. Remove angled eccentric shaft by removing 6mm bolt with an allen wrench and lifting off.
5. Remove the crankshaft using an industrial press. Gently tap the end of the shaft until shaft releases from the crankcase. **(Fig. C)** The bearing usually comes out with the shaft. To remove the shaft from the bearing, support both sides of bearing and press or tap shaft out of the bearing.
6. Remove oil seal by working around the edges with a small flat-headed screwdriver. Lift out once completed. Replace the oil seal once it is removed.

H. Crankcase Reassembly

1. Assemble shaft/bearing assembly. Stack all of the shaft & bearing components. Secure using the 6mm allen bolt & wrench. Place LOCTITE 243 on the bolt before threading. Torque to 18 ft. lbs. **(Fig. D)**
2. Insert large bearing into crankcase. Lubricate and press into place.
3. Insert lubricated shaft into bearing and press into place. **(Fig. E)**
4. Assemble the piston guide, spring, washer & snap ring. Slide the piston assembly into the piston holes as explained in 6.1-E.
5. Press the two halves of the crankcase together compressing the springs. Secure the 6mm bolts with an allen key. Torque to 18 ft. lbs. **(Fig. A)**

I. Unloader Maintenance

1. To service the unloader, simply take a 22mm wrench and remove the cartridge just above the manifold. **(Fig. F)** Remove this piece and replace it with new unloader cartridge Comet part# 1215.0271.00



Fig. D



Fig. E

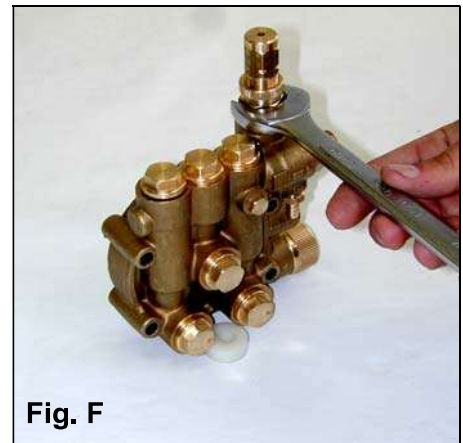

Fig. F

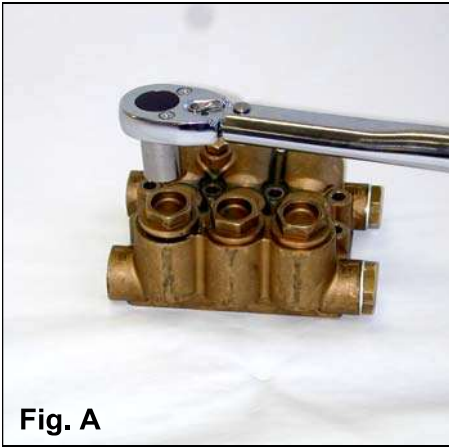

Fig. A

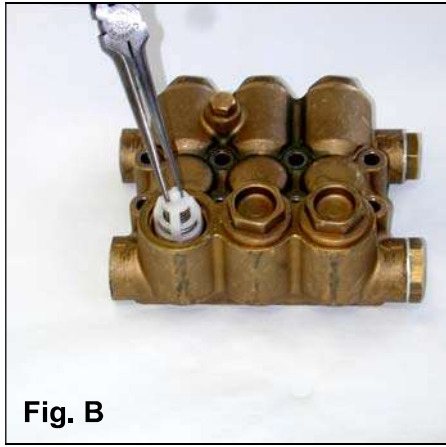

Fig. B



Fig. C

6.2 LW/ZW SERIES PUMP

A. Valve Maintenance

1. Using a 22mm wrench or socket, remove the six valve caps on manifold of pump. **(Fig. A)**
2. Examine the valve cap o'ring for cuts or distortions and replace if worn.
3. Using a needle nose pliers, remove the suction and delivery check valve. The valve assembly usually stays together when removing. If the valve comes apart, use a needle nose pliers or a reverse pliers to remove the remaining parts. **(Fig. B)**
4. Inspect the suction and delivery check valve assembly for general wear and replace if necessary. The valve assembly consists of the plastic cage, spring, valve seat, poppet and o'ring. **(Fig C)** One Comet valve kit is needed for complete valve change of one pump.
5. Replace old valves with new valves by placing assembly in the valve chamber. Press down firmly on the top of the valve assembly. **(Fig. D)**

6. Replace valve caps by applying LOCTITE 243 to valve cap and torque to 33 ft. lbs.

B. Removing & Replacing Pump Manifold

1. Remove the manifold of the pump by taking a 5mm allen head wrench and removing the eight head bolts.
2. With the pump firmly secured, take a medium sized flat head screwdriver and apply pressure to the manifold by prying between the crankcase and manifold. Work around from all sides of the manifold evenly until it comes off of the pistons. Keep manifold properly aligned with the pistons to prevent damage to the seals and pistons. **(Fig. E)**
3. When replacing the manifold, turn crankshaft of pump until the top of pistons are closely aligned. Lubricate the pistons and cylinders with grease and evenly press the manifold toward crankcase until flush. **(Fig. F)**

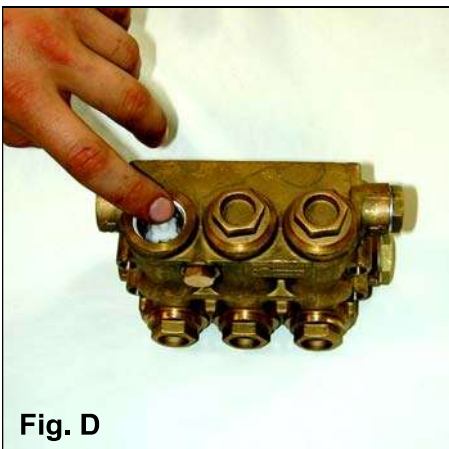

Fig. D

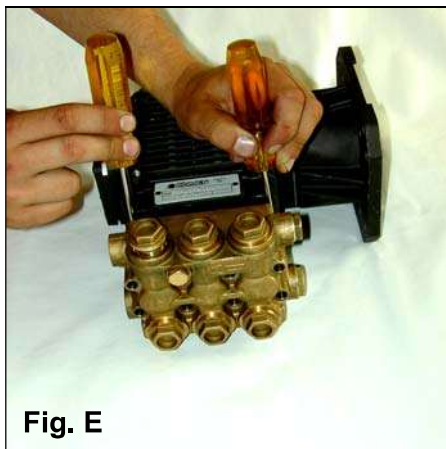

Fig. E



Fig. F

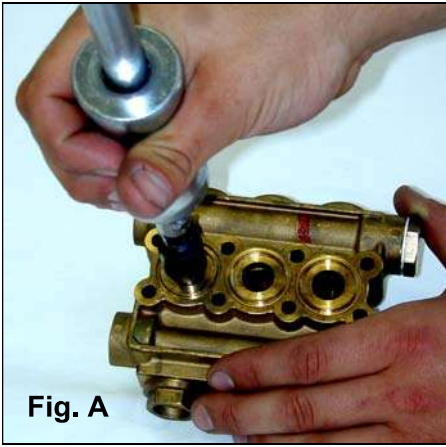

Fig. A

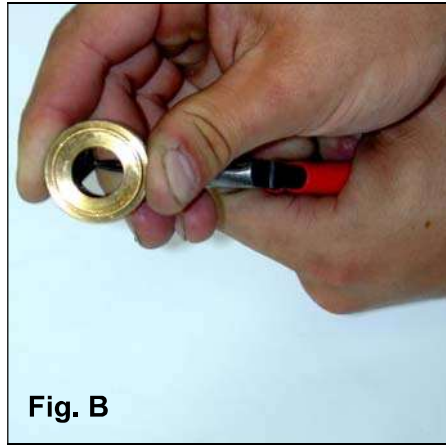

Fig. B

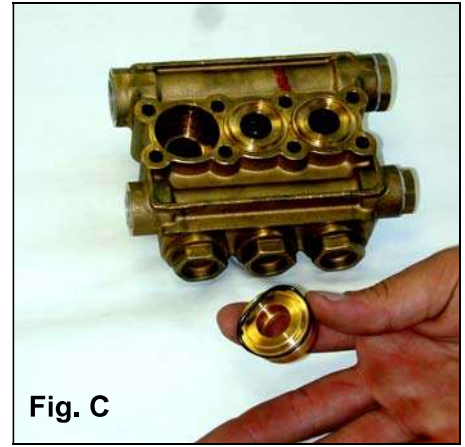

Fig. C

C. Seals and V-Packing Maintenance

1. Remove the manifold as described in section 6.2-B. It is possible that the seal and brass retainer ring assembly stays on the piston or remains in the manifold when removing.
2. Using the packing extraction tool, remove the brass retainer ring/seal stack. **(Fig. A)** Remove the low-pressure seal using a needle nose pliers. **(Fig. B)** Once this seal is removed, replace with a new seal.
3. Remove the outer o-ring by taking a small flat head screwdriver and working it under the o-ring. Simply roll off the o-ring. **(Fig. C)**
4. The V-packing stack can be taken apart by hand.
3. Replace the outer o-ring by simply starting on one side and working it into the groove. **(Fig. C)**
4. Stack the V-packing in the correct order and firmly press the assembly into the manifold. **(Fig. D)**
5. Install a new oil seal by laying the seal into the opening and evenly pressing it into place. **(Fig. E)**
6. Reinstall the manifold onto the pump as described in section 6.2-B.

D. Seals and V-Packing Reassembly

1. Generously lubricate parts with grease when reassembling. Examine brass components for any damage or water residue build-up.
2. Insert low-pressure sealing working it in by hand.

E. Plunger Maintenance

1. Remove the manifold as described in section 6.2-B. Remove the packing retainers if they remain on the pistons after removing the manifold.
2. Remove the nut and washer on the end of the piston using a 13mm wrench or socket.
3. Slide the ceramic plunger and the remaining washer from the piston guide. Inspect ceramic piston, o-ring and washers for wear. Replace if necessary. **(Fig. F)**



Fig. D



Fig. E

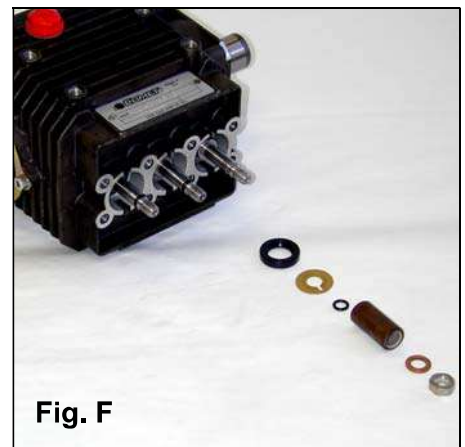

Fig. F

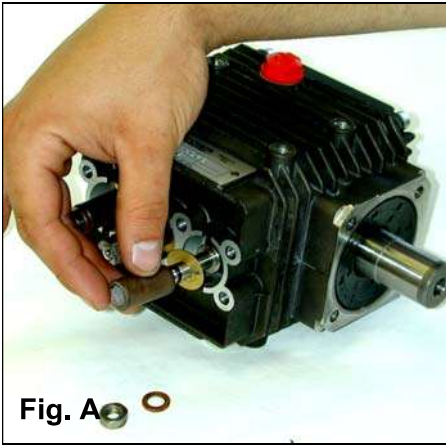

Fig. A

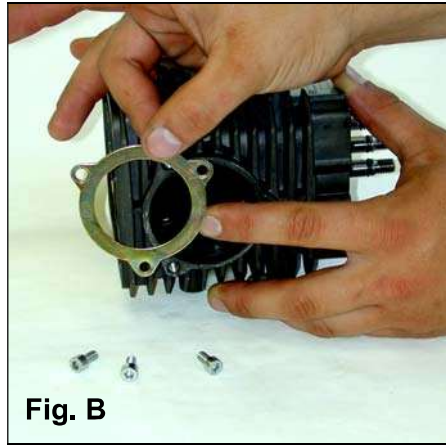

Fig. B



Fig. C

F. Plunger Reassembly

1. Generously grease the piston guide. Replace the o'ring making sure it does not twist or roll.
2. Slide the lower washer and ceramic bushing onto the piston guide. **(Fig. A)**
3. Place a small amount of LOCTITE 243 on the piston guide threads. Replace the outer washer and thread the nut onto the piston guide. Torque to 4.5 ft. lbs.

G. Crankcase Maintenance

1. Remove manifold & pistons as described in sections 6.2-B, 6.2-E.
2. Remove the plastic bearing cover ring using 4mm allen wrench to unscrew the three bolts. **(Fig. B)**
3. Remove plastic spacer and o'ring by hand.
4. Remove the snap ring from end of crankshaft allowing the shaft to slide out of the bearing. **(Fig. D)**
5. On the flange side of the pump, remove the oil seal by piercing a hole in the surface of

the oil seal with a flat head screwdriver. Pry it out of the crankcase and over the shaft. **(Fig. E)**

6. Remove the large snap ring securing the flange side bearing into the crankcase.
7. Remove the small snap ring securing the shaft to the bearing.
8. Using an industrial press, or something equivalent, press out the shaft from the side where the plastic cover was removed. Secure the smaller bearing to the crankcase using a vise grips, or something equivalent, to make sure the smaller bearing does not get pushed into the crankcase with the shaft. **(Fig. F)** The larger bearing on the flange side of the pump will likely come out with the shaft.
9. Work the shaft out of connecting rods as needed.
10. Remove the piston guides by pulling out by hand.
11. Press the small bearing out of the crankcase going through the larger bearing opening and pressing out.

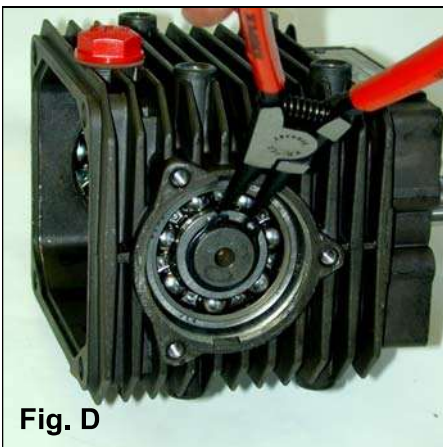

Fig. D

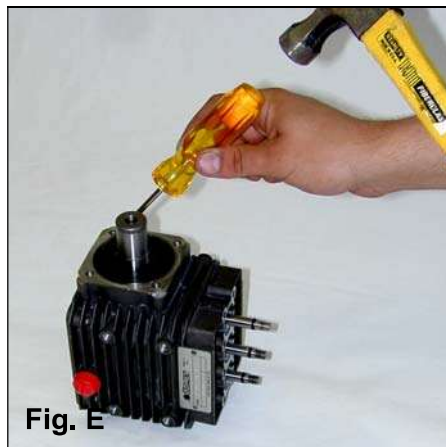

Fig. E

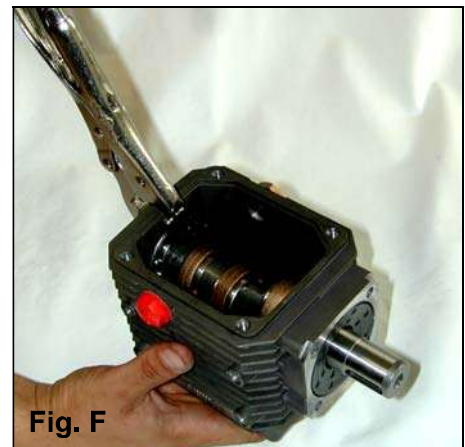
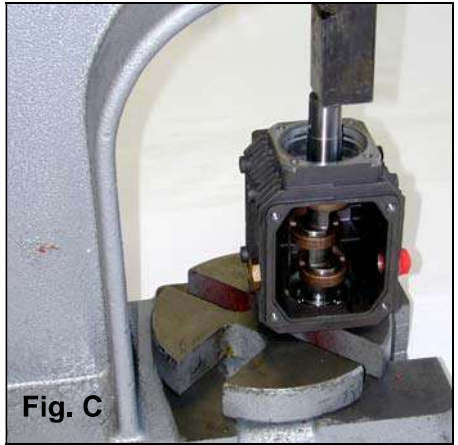
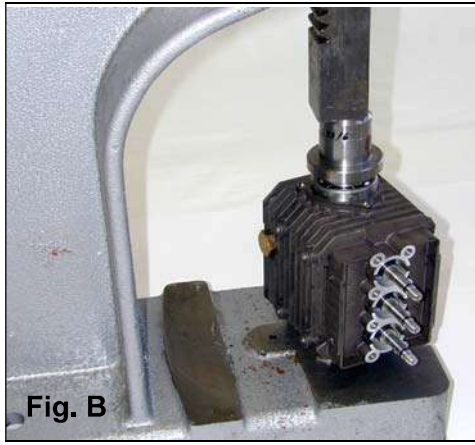
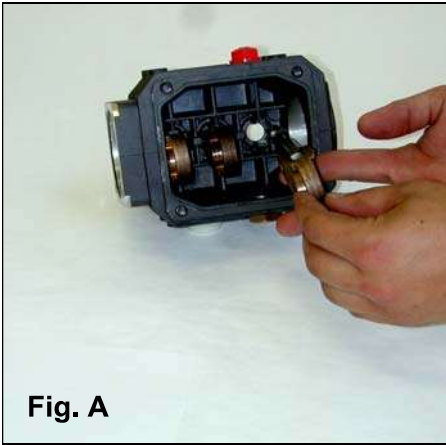
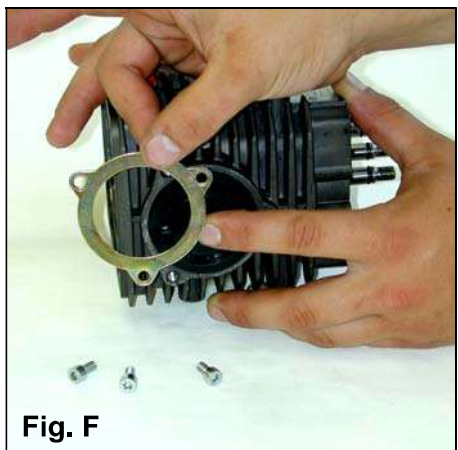
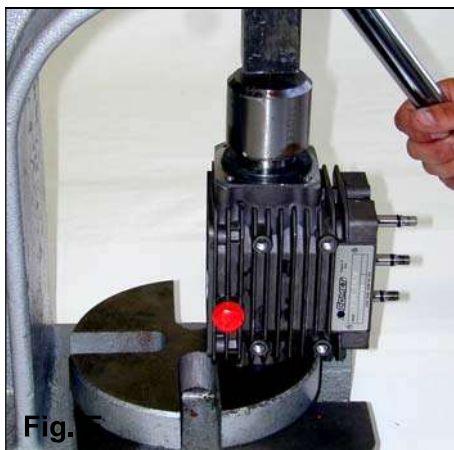
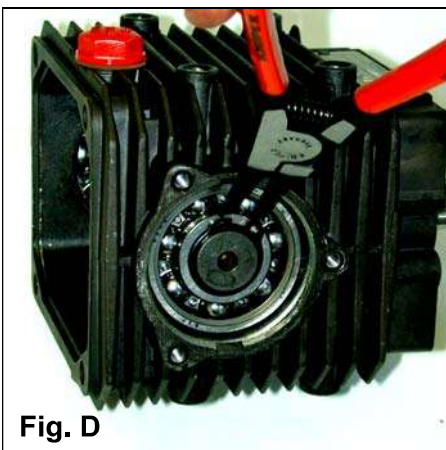

Fig. F



H. Crankcase Reassembly

1. Insert the piston guides by sliding them into the crankcase by hand. **(Fig A)**
2. Press the small bearing into the crankcase. **(Fig B)**
3. Insert the crankshaft through the large bearing opening, eyeing it through the connecting rod openings. Press the end of the shaft down into small bearing. **(Fig C)**
4. Secure the snap ring around the shaft outside of the small bearing. **(Fig D)**
5. Slide the large bearing over the crankshaft and press it into the crankcase.
6. Secure the snap rings into place by securing the bearing into the crankcase, and the shaft into the bearing.
7. Install the large oil seal on the flange side of the crankcase to cover the large bearing. **(Fig E)**
8. Install the plastic spacer, o'ring and metal cover. Secure the three bolts with a 4mm allen wrench. Torque to 3 ft. lbs. **(Fig F)**
9. Install the large crankcase back cover by placing the o'ring outside of the inner lip. Secure with the four 5mm bolts and torque to 7 ft. lbs.



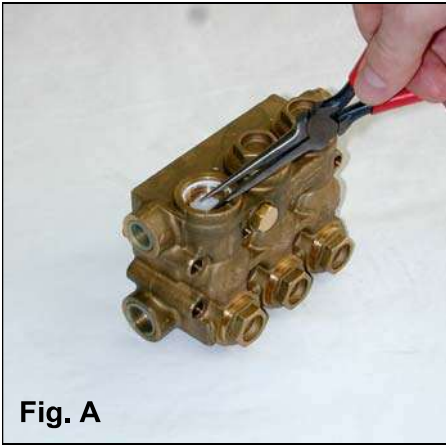

Fig. A

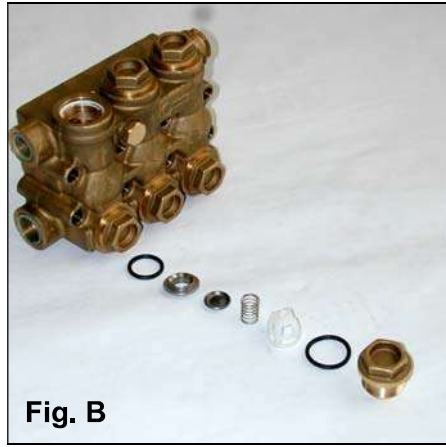

Fig. B

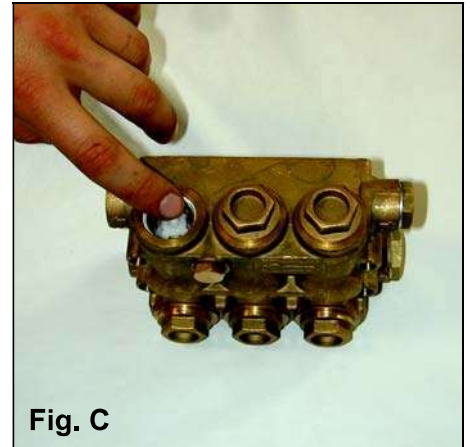

Fig. C

6.3. FW/HW SERIES PUMP

A. Valve Maintenance

1. Using a 22mm wrench, remove the six valve caps on manifold of pump.
2. Examine the valve cap o’ring for cuts or distortions. Replace if worn.
3. Using a needle nose pliers, remove the suction and delivery check valve. The valve assembly usually stays together when removing. If the valve comes apart, use a needle nose pliers or a reverse pliers to remove. **(Fig. A)**
4. Inspect the suction and delivery check valve assembly for general wear and replace if necessary. The valve assembly consists of the plastic cage, spring, valve seat, poppet and o’ring. One Comet valve kit is needed for a complete valve change of one pump. **(Fig. B)**
5. Insert new valve assemblies by simply placing the assembly in the valve chamber. Press down firmly on the top of valve assembly. **(Fig. C)**

6. Replace valve caps by applying LOCTITE 243 to valve cap and torque to 33 ft. lbs.

B. Removing & Replacing Pump Manifold

1. Remove the manifold of the pump by taking a 6mm allen head wrench and removing the eight head bolts.
2. With the pump firmly secured, take a medium sized flat head screwdriver and apply pressure to the manifold by prying between the crankcase and the manifold. Work around from all sides of the manifold evenly until it comes off of the pistons. Keep manifold properly aligned with the crankcase to prevent damage to the seals and pistons. **(Fig. D)**
3. When replacing the manifold, turn crankshaft of pump until the top of pistons are closely aligned. Lubricate pistons and cylinders and evenly press the manifold toward crankcase until flush. **(Fig D)**

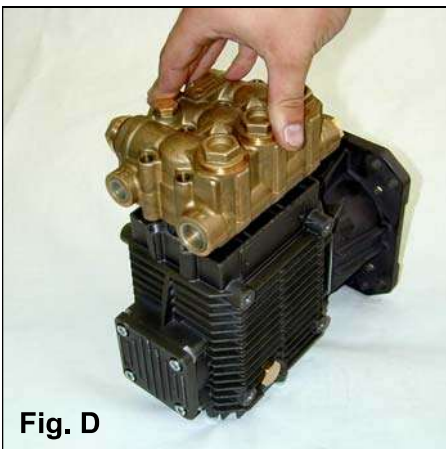

Fig. D

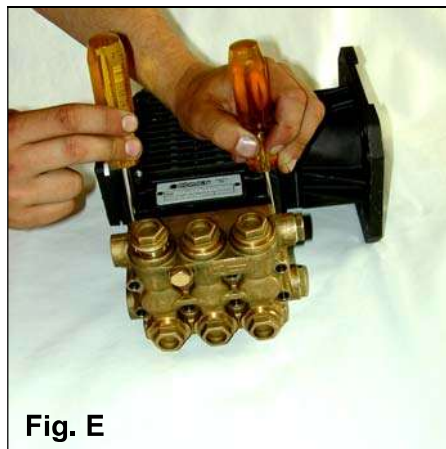

Fig. E



Fig. F

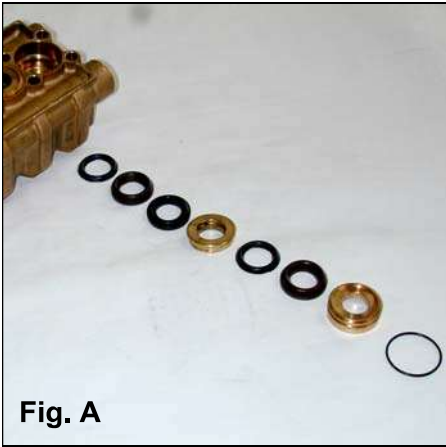

Fig. A

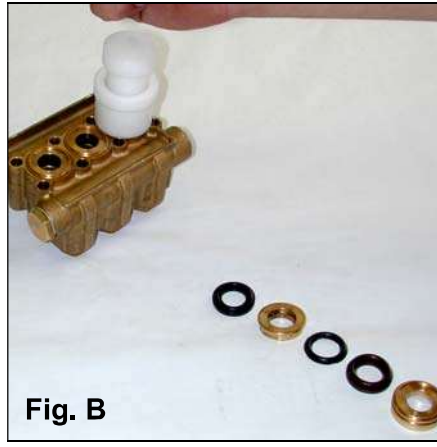

Fig. B

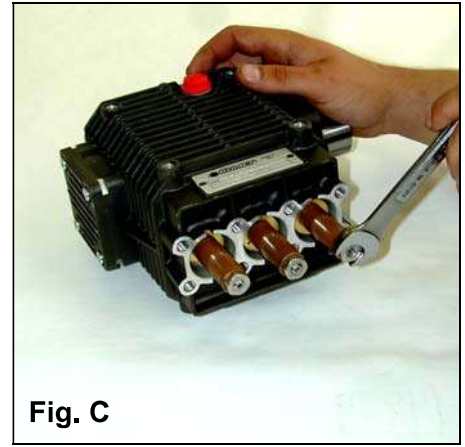

Fig. C

C. Seals and V-Packing Maintenance

1. Remove manifold as described in section 6.3-B. It is possible that the seal and brass retainer ring assembly stays on the piston or remains in the manifold when removing.
2. Using the packing extraction tool, remove the brass retainer ring/seal stack. Remove the low-pressure seal using a needle nose pliers. Once this seal is removed, replace with a new seal.
3. Remove the outer o'ring by taking a small flat head screwdriver and working it out. Simply roll off the o'ring.
4. The V-packing can be taken apart by hand.

5. Reinstall the manifold onto the pump as described in section 6.3-B

E. Plunger Maintenance

1. Remove manifold as described in section 6.3-B. It is possible that the seal and brass retainer ring assembly stays on the piston or remains in the manifold when removing.
2. Remove the 15mm nut and washer on the end of piston. **(Fig. C)**
3. Slide the ceramic plunger and remaining washer from the piston guide. Remove the o'ring by taking a small flat head screwdriver and work it off of the piston guide.
4. Inspect ceramic piston, o'ring and washers for wear. Replace if necessary **(Fig. D)**

D. Seal and V-Packing Reassembly

1. Generously lubricate parts with grease when reassembling. Examine brass components for any damage or water residue build-up.
2. Insert the low-pressure seal into the retainer ring, working it in by hand.
3. Stack V-packing in correct order and firmly press assembly into manifold. **(Fig. A & B)**
4. Install a new oil seal by laying seal into the opening and pressing it into place. **(Fig. F)**

F. Plunger Reassembly

1. Generously grease piston guide. Replace o'ring making sure it does not twist or roll.
2. Slide the lower washer and ceramic bushing onto the piston guide. **(Fig. E)**
3. Place a small amount of LOCTITE 243 on the piston guide threads. Replace the outer washer and thread the nut onto the piston guide. Torque to 4.5 ft. lbs.

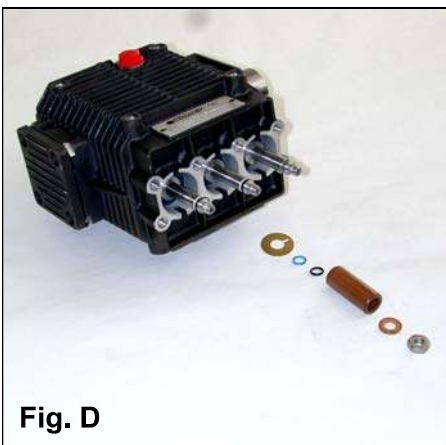

Fig. D

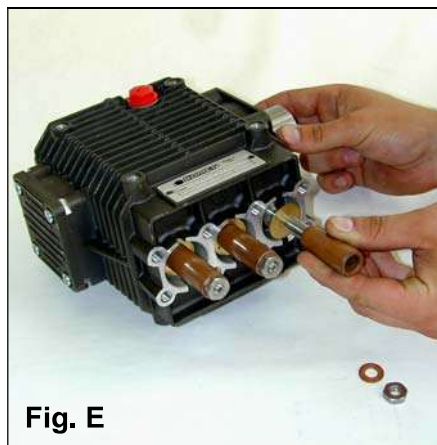
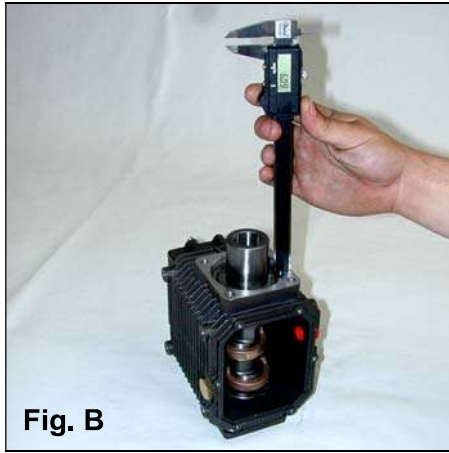
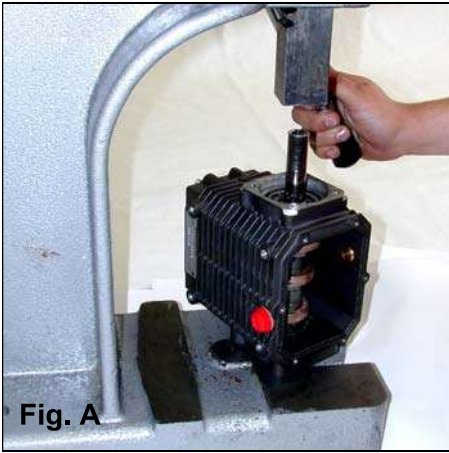

Fig. E



Fig. F



F. Crankcase Maintenance

1. Remove manifold and pistons as explained in sections 6.3-A and 6.3-B.
2. Remove crankcase back by removing the six 4mm allen bolts.
3. Remove the mounting flange by unscrewing the four 6mm allen bolts.
4. Remove the side crankcase cover by unscrewing the four 5mm allen bolts. Pry off the cover with a flat head screwdriver.
5. Press out shaft from opposite flange side of the pump. Use a socket that will fit inside the perimeter of the end of shaft. **(Fig. A)**
6. Work the shaft out of the connecting rods eyes. The flange side bearing will come out with the shaft.
7. Remove the small bearing opposite flange bearing by tapping it out.

G. Crankcase Reassembly

1. Install the piston guides and connecting rods by sliding through the piston holes in the crankcase. **(Fig. F)**
2. Press the small, non-motor side bearing into place. The inner parts of the bearing will float until the shaft is installed.
3. Place the bearing cover into place and secure the four bolts onto cover. **(Fig. D)**
4. Install the crankshaft by eyeing it through the connecting rods and pressing it into the small bearing opposite of the flange.
5. Install the larger tapered bearing. Press the inner portion of the bearing onto the shaft.
6. Place outer portion of bearing into place and press into crankcase using the flange between the press and the bearing. **(Fig. E)**
7. Remove flange and measure pump for any shims that may be needed. The flange must not press too tightly against the bearing or the performance of the pump may be altered. Using a caliper, measure the distance from the top of the bearing to the edge of the crankcase where the flange will sit flush. **(Fig. B)** Next measure inside peak of flange and the flange portion that will sit flush onto the crankcase. **(Fig. C)** The flange peak may be taller than the distance from the top of the bearing to the top of the crankcase. Use the shims to make-up the difference.
8. Install the flange onto the pump by securing the four bolts.
9. Replace the rear cover of the crankcase by securing the six 4mm allen bolts

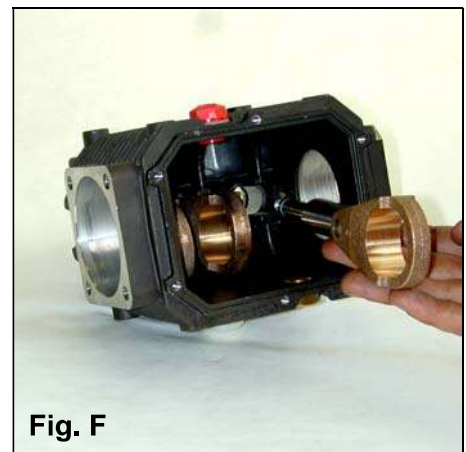
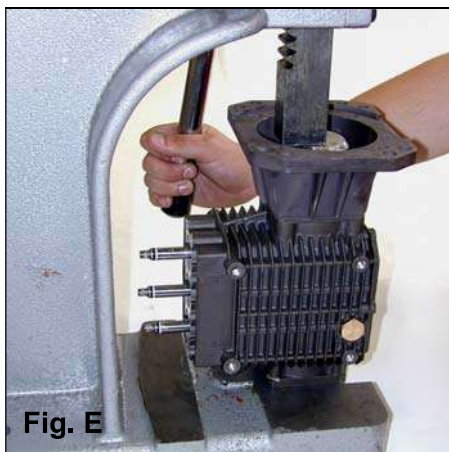
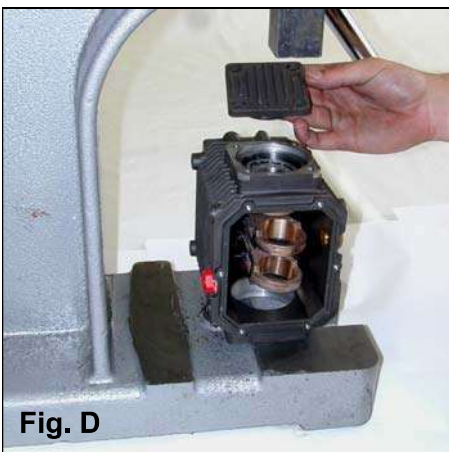

7. PUMP LIMITED WARRANTY

7.1 *Comet Pump Limited Warranty*

The Comet pump is warranted by the manufacturer to the original purchaser to be free from defects in material and workmanship under normal use and service. "Normal use and service" means not in excess of the recommended maximum speeds, pressures and temperatures or handling fluids not compatible with component materials. This warranty shall not apply to any pump that has been repaired or altered to affect the performance or reliability of the pump.

The period of Limited Warranty on AXD models shall be one year from the date of sale to the end user. Liability of manufacturer under the foregoing warranty is limited to repair or replacement at the option of the manufacturer of that product, which according to the manufacturer's investigation was deemed defective at the time of shipment. This warranty is in lieu of all other warranties, expressed or implied, including any warranty of merchantability and/or any and all other obligations or liabilities on the part of the manufacturers.

The period of Limited Warranty on the LW, ZW,FW & HW models shall be five years from the date of sale to the end user. Liability of manufacturer under the foregoing warranty is limited to repair or replacement at the option of the manufacturer of that product, which according to the manufacturer's investigation was deemed defective at the time of shipment. This warranty is in lieu of all other warranties, expressed or implied, including any warranty of merchantability and/or any and all other obligations or liabilities on the part of the manufacturers.

7.2 *Limited Warranty Conditions*

- a. Pump operation must be within the maximum RPM, discharge pressure and inlet pressure specifications. A pressure relief valve must be properly installed in the system.
- b. The pump must be operated with sufficient fluid to the manifold. Do not pump aggressive fluid that may cause premature wear to the internal components.
- c. The oil level in the crankcase must be maintained at the correct level according to Comet specifications for proper lubrication.
- d. The pump must be protected from freezing. Flush the system with propylene glycol antifreeze before storing in freezing conditions. Use the following concentration: 14° F-25% 5°F-33% minus 25°F-50%

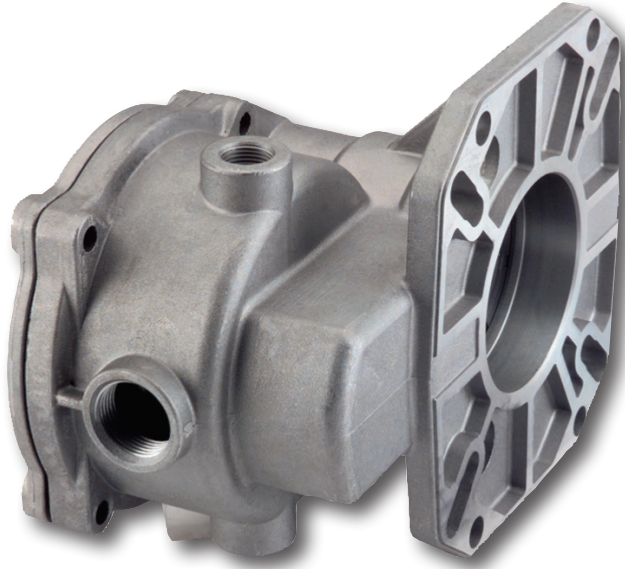

FEATURES

- Compact and lightweight
- Hardened steel helical gears for quiet operation
- Oil bath lubrication
- Dual bearing design for extended life
- J609a Flange mounts to most gasoline engines

SPECIFICATIONS

Part Number	YGR1000	YGR1000P	YGR1125	YGR1125P	YGR1125P31
Drive Ratio	2.176:1				
Horsepower	11 - 18	18 - 24	11 - 18	18 - 24	24 - 31
Input (motor) Shaft Ø"	1.0" / 25.4 mm		1.125" / 28.6 mm		
Output (pump) Shaft Ø"	24 mm				
Motor Flange (SAE)	J609A				
Pump Flange	Fits 47, 47SS and 66 Series General Pump				
Oil Grade	SAE90 Gear Lube				
Oil Capacity	10 oz				
Weight	5.8 lbs.				

DIMENSIONS

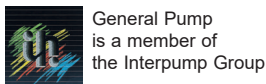
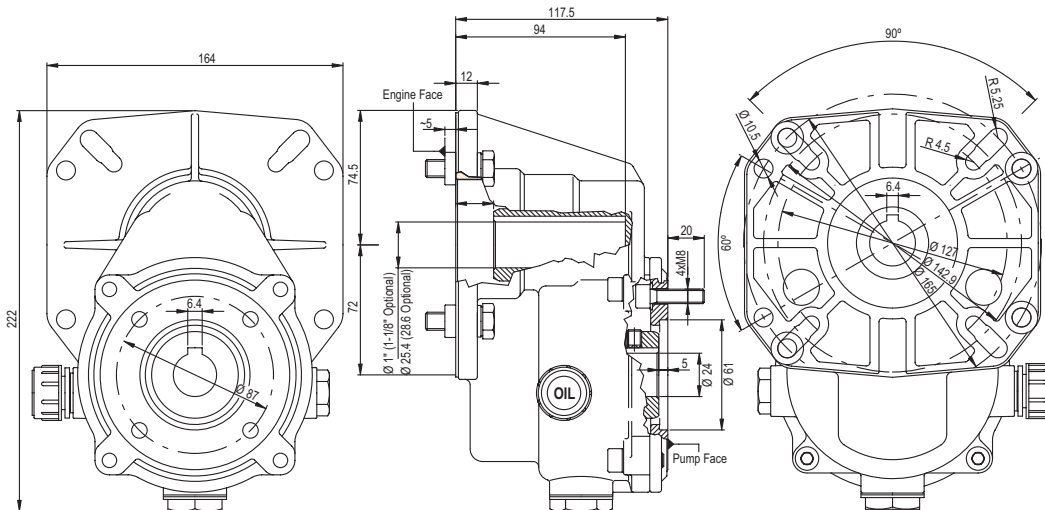

Ref 300178 Rev. E
05-22



YGR1000/1125

GENERAL PUMP *A member of the Interpump Group*

Gear Reducer

PARTS LIST

NOTE: A RTV gasket sealant should be applied to inner flange mounting screws/washer to ensure proper sealing

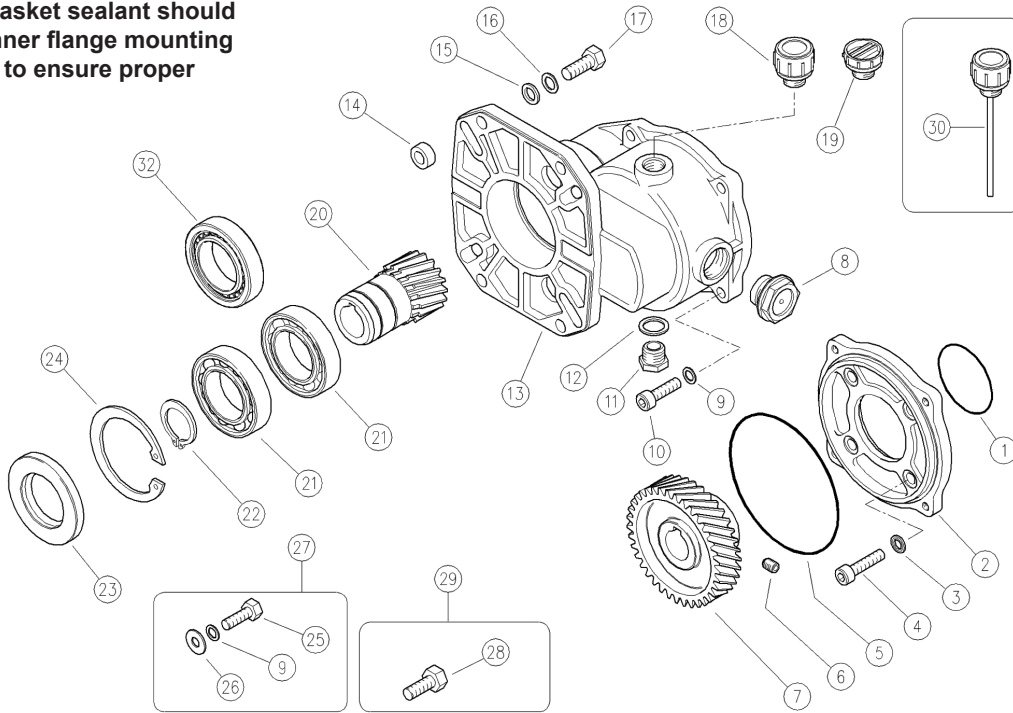

NO.	PART #	DESCRIPTION	QTY.	NO.	PART #	DESCRIPTION	QTY.
1.	Y10321056	O-ring	1	18.	Y15372600	Oil Plug + Seal	1
2.	Y50000244	Flange	1	19.	Y15372500	Plastic Cap, 3/8"	1
3.	Y14409800	Washer, 8 mm	4	20.	Y50000621	Gear, 1"	1
4.	Y16195831	Screw, M8 x 30 mm	4		Y50000721	Gear, 1-1/8"	1
5.	Y10321111	O-ring	1	21.	Y11444068	Bearing (standard)	2
6.	Y16222300	Screw, M8x10	1		Y11444168	Bearing ("P" models)	2
7.	Y50000365	37 Gear, 24 mm	1		Y11444168	Bearing ("P31" model)	1
8.	Y15373400	Oil Plug	1	22.	Y10104000	Ring, Elastic, 40 mm	1
9.	Y14365200	Washer, 8.4 mm	8	23.	Y10204072	Seal, 40 mm	1
10.	Y16195826	Screw, M8x25 mm	4	24.	Y10107200	Ring, Elastic, 40x72 mm	1
11.	Y60002831	Plug, 3/8 BSP	1	25.	Y16200900	Screw, 5/16"x1	4
12.	Y14404200	Washer, 16.7x22 mm	1	26.	Y14357200	Washer, 8.4x21 mm	4
13.	Y50000144	Housing	1	27.	Y50001024	Kit, 5/16" D, 127 mm	1
14.	Y50000831	Spacer	4	28.	Y16203500	Screw, M10	4
15.	Y14379800	Washer, 10.5x17 mm	4	29.	Y50001124	Kit, D, 135 mm, M10	1
16.	Y14365300	Washer, 10.5 mmx16 mm	4	30.	Y15372800	Oil Plug	1
17.	Y16201000	Screw, 3/8"x1-1/4	4	32.	Y11444568	Bearing (P31 model)	1

Ref 300178 Rev. E
05-22

GENERAL PUMP 1174 Northland Drive • Mendota Heights, MN 55120
Phone: 651.686.2199 • Fax: 800.535.1745 • e-mail: sales@gpcompanies.com • www.generalpump.com



GENERAL PUMP *A member of the Interpump Group*

YU21405S

Trapped Pressure Unloader Valve

FEATURES

- NEW improved design!
- Reduced pressure loss
- Makes for easier gun operation
- Extremely reliable
- Stainless Steel inlet and outlet fittings



SPECIFICATIONS

PART NUMBER		YU21405S
Maximum Volume*		21 GPM
Rated Pressure		4050 PSI
Maximum Pressure		4500 PSI
Maximum Temperature		200° F
<p>Note: The valve has been designed for continuous use at a water temperature of 140° F. It can operate for short periods at a maximum temperature of 195° F.</p>		
Port Sizes	Inlet	(2) 1/2" NPT-F
	Outlet	1/2" NPT-F
	Bypass	(2) 1/2" NPT-F
Overall Dimension		7.57" x 3.96" x 1.5"
Weight		3.1 Lbs.

General Pump recommends using a pressure reducing device in conjunction with this unloader valve when installed on a positive displacement pump. General Pump is not liable and assumes no responsibility when used in a customer's high pressure system.

*NOTE: If unloader is fed through the lower connection max flow rate: 10.5 GPM / 40 l/min

PARTS LIST

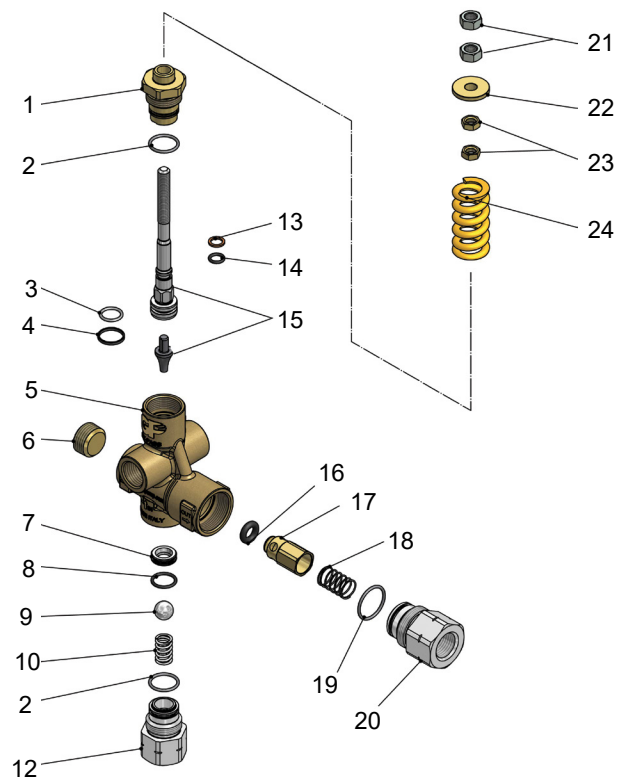

No	Part No.	Description	Qty.
1	Y60049131	Piston Holder, Brass	1
2	Y10306801	O-ring, 1.78 x 17.17 mm	2
3	Y10306000	O-ring	1
4	Y10416100	Back-up Ring, 18 mm	1
5	Y60046735	Housing, NPT-F, Brass	1
6	Y60044431	Plug	1
7	Y60280351	Seat, 10 mm	1
8	Y10306401	O-ring, 1.78 x 14 mm, Ni	1
9	Y14746500	Ball, 1/22", SST	1
10	Y30530451	Spring, 2 x29 x 9.9 mm, SST	1
12	Y60049651	Inlet Coupling, 1/2" NPT-F, SS	1
13	Y10400800	Back-up Ring, 18 x 11 x 1.2 mm	1
14	Y10305500	O-ring, 1.78 x 7.66 mm	1
15	Y60049221	Piston, SST	1
16	Y10329200	O-ring, 4 x 8 mm	1
17	Y60048899	Check Valve, Brass & O-ring	1
18	Y60048951	Spring, 0.8 x 13.3 x 27, SST	1
19	Y10307250	O-ring	1
20	Y60185251	Check Valve Coupling, 1/2 NPT-F, SS	1
21	Y11457400	Hex Nut, M8	2
22	Y60001131	Spring Holder Ring, Brass	1
23	Y11457331	Washer	2
24	Y60044961	Spring, YU21235	1
	Y60046961	Spring, YU21405	1
*	YUKIT215	Repair Kit	

DIMENSIONS

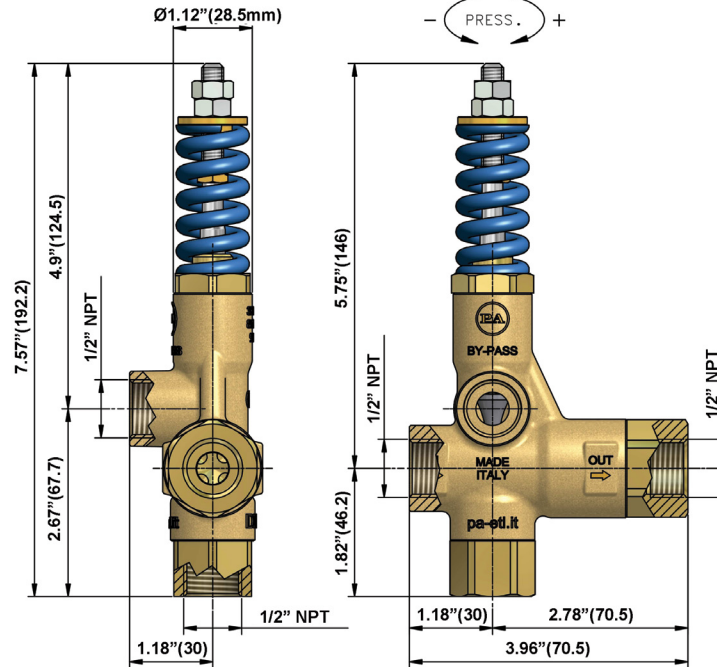

SELECTION AND OPERATION

SELECTION

This product is intended to be incorporated on a finished machine. This product is to be used with clean fresh water, for use involving different or corrosive liquids, contact the GP Customer Service Department. Appropriate filtration should be installed when using impure liquids. Choose the valve appropriate to the working data of the pump (permissible pressure, flow and rated temperature of the system). The pressure of the pump must not exceed the maximum pressure of the valve.

OPERATION

The valve regulates the maximum pressure of the system by varying the flow discharged by the bypass. The adjustment is made by altering, by means of a piston, the position of a sphere which partially closes the bypass opening. The valve is sensitive to water flow. At gun opening, the water flows through the valve which maintains the system in pressure until the gun closes, the interruption of the flow provokes the complete aperture of the bypass which allows to discharge the flow at low pressure. At gun closure, the special mechanism of zero setting, which does not include a check valve, keeps in connection the delivery line and the bypass line, in that way permitting to lower the pressure all around the system and not only in the source line of the valve.

INSTALLATION

This valve, on a system that produces hot water, must be fitted upstream from the source of heat. On a system that generates hot water, it is advisable to use accessories that limit the accidental increase of fluid temperature. **Always install a safety valve.** We recommend the use of a nozzle with flow rate which allows a regular discharge from the valve bypass of at least 5% of the flow supplied by the pump. In order to achieve a constant pressure and easy adjustment. If the nozzle wears out, the pressure decreases. To reset pressure back to working level, it is necessary to replace the worn nozzle. When a new nozzle is fitted, resetting of the system to its original working pressure is required.

DISCHARGE SYSTEM AND WATER ADDUCTION

The bypass discharge can be sent back to the pump intake or returned into a tank; in such cases it is advisable that the tank be fitted with baffles to reduce eventual turbulence and air bubbles which could be harmful to the pump.

PRESSURE ADJUSTMENT/CALIBRATION

The desired working pressure must be adjusted with the system running and the gun opened. Adjust the pressure by screwing or unscrewing the adjustment knob. The operation is easier if the correct nozzle has been chosen (see above). When screwing the adjustment nut a consequent pressure increase must be matched. If, before reaching the desired pressure, there is no pressure increase, DO NOT FORCE. Rather, check the correct ratio of nozzle/flow rate - pressure and, if necessary, replace with a smaller size nozzle.

ATTENTION: the nut in position 21 is a mechanical security device that limits the maximum pressure; it must absolutely NOT be removed.

MAINTENANCE

STANDARD: every 400 working hours, check and lubricate the seals with water resistant grease.

SPECIAL: every 800 working hours, check the wear of the seals and internal parts and, if necessary, replace with original GP parts taking care, during installation, to lubricate with water resistant grease.

The manufacturer is not to be considered responsible for damage as a result from incorrect fitting and maintenance.

TROUBLESHOOTING

PROBLEMS	PROBABLE CAUSES	SOLUTIONS
Frequent valve recycles	<ul style="list-style-type: none"> • Damaged check valve O-ring • Leaking connections • Restricted bypass or too small diameter of the bypass hose 	<ul style="list-style-type: none"> • Replace • Check or renew • Clean or adapt passage diameter
Valve does not reach pressure	<ul style="list-style-type: none"> • Piston O-rings worn out • Debris between seat and shutter • Seat worn out • Nozzle worn out • Incorrect choice of nozzle 	<ul style="list-style-type: none"> • Replace • Clean the seat • Replace • Replace • Fit with smaller nozzle
High pressure peaks at gun closure	<ul style="list-style-type: none"> • There is not a minimum of 5% of total flow discharged in bypass • Excessive flow in bypass • Adjustment with spring totally compressed 	<ul style="list-style-type: none"> • Reset Correctly • Change type of valve or adjust passages • Loosen adjustment screw and eventually fit with smaller nozzle
Valve does not discharge at low pressure at gun closure	<ul style="list-style-type: none"> • Jammed check valve • Debris on check valve 	<ul style="list-style-type: none"> • Clean or replace • Clean

WARNING: High Pressure Systems require a primary pressure regulating device (i.e. regulator, unloader) and a secondary pressure relief device (i.e. pop-off valve, relief valve). Failure to install such relief devices properly could result in personal injury or damage to pump or property. GP does not assume any liability or responsibility for the operation of the user's high pressure system.



WARNING: This product can expose you to chemicals including lead, which is known to the state of California to cause cancer and birth defects or other reproductive harm. For more information, go to www.P65Warnings.ca.gov



Frame Assembly Spare Parts

Part # 1000157



Part # 4800017



Part # 9800386

Parts numbers can be found on Dirtkiller.com

RW5535 Pump Assembly Spare Parts Breakdown



3



2



4



8

9

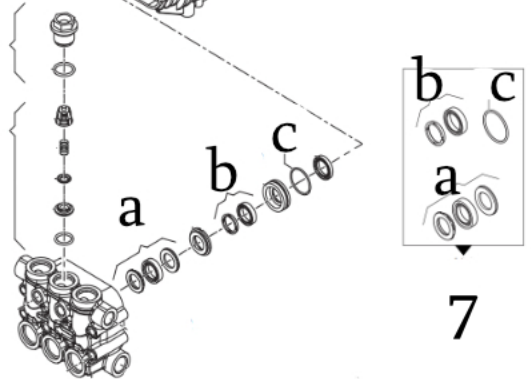
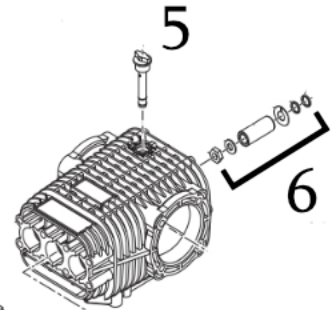

7

12 14

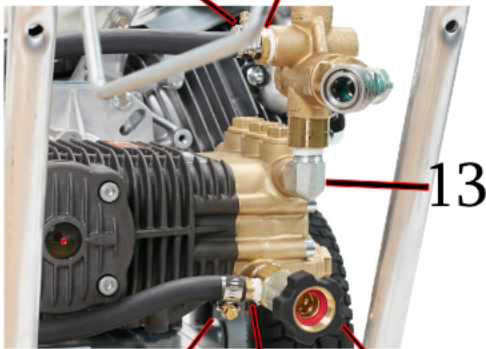

12 11 10

15

16 17

18

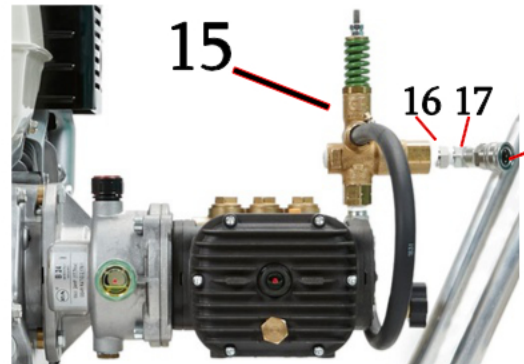

19



20

Manual #	Dirtkiller.com #	Description	Manual #	Dirtkiller.com #	Description
1	6600157	Complete pump assembly	11	5100293	1/4" MNPT x 3/8" Inlet Barb
2	6600250	Gear box	12	3000112	Hose clamp
3	5000447	Gear box breather cap	13	5100474	90° Elbow 1/2" MNPT x 3/8" MNPT
4	3300200	Gear box hardware kit	14	5100658	3/8" MNPT x 3/8" Bypass Barb
5	5000320	Dipstick (breather)	15	5000406	Green spring unloader
6	9800360	Plunger kit	16	5100480	1/2" MNPT x 3/8" FNPT Bushing
7	9800713	Water seal kit	17	5100470	45° Elbow 3/8" FNPT x 3/8" MNPT
8	5000322	Valve cap + O-ring	18	5100211	3/8" Stainless steel socket
9	9800724	Check valve kit	19	8100117	Gear box lube
10	5500026	1/2" Water inlet w/ bypass ports	20	8100119	Comet pump oil

Parts numbers can be found on Dirtkiller.com

GX390 Engine Spare Parts Breakdown



1



2

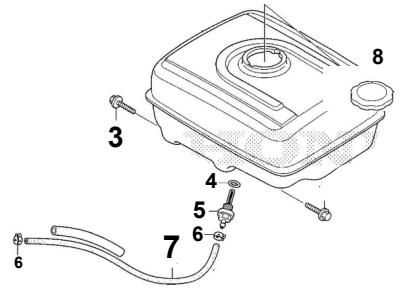

8



9

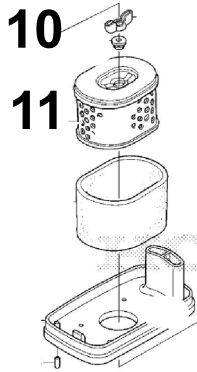

10

11

12



13

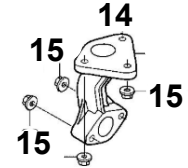

14

15

15

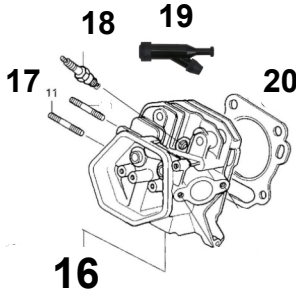

18

19

20

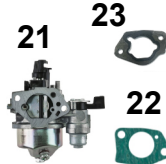

21

23

22

24

25

16

29

33

36

26

27

28

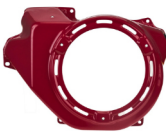

29

33

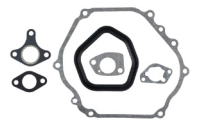

36



28

31

30

34

37

26

27

28

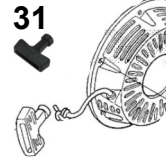

31

30

34

37

34

35



32

Manual #	Dirtkiller.com #	Description	Manual #	Dirtkiller.com #	Description
1	6600010	Replacement engine	20	3600146	Head gasket
2	3600138	Fuel tank	21	3600205	Carburetor assembly
3	3600231	Fuel tank bolt	22	3600125	Carburetor gasket
4	3600123	Fuel tank o-ring	23	3600229	Carburetor spacer
5	3600121	Fuel tank filter	24	3600180	Throttle control assembly
6	3600167	Fuel line clip	25	3600104	Throttle return spring
7	3600203	Fuel tube	26	3600227	Valve rotator
8	3600210	Gas filler cap	27	3600216	Cam shaft
9	3600148	Air filter housing assembly	28	3600176	Crankcase gasket
10	3600141	Wing nut for air filter	29	3600181	Motor fan shroud cover
11	5500107	Air filter	30	3600111	Recoil assembly
12	3600139	Muffler	31	3600207	Handle/grip for recoil
13	3600194	Exhaust deflector	32	3600130	Flange bolt for recoil assembly
14	3600126	Riser pipe	33	3600144	Ignition coil assembly
15	3600162	Muffer nuts	34	3600152	Engine stop switch assembly
16	3600222	Cylinder head assembly	35	3600157	Shaft key for 1" shaft
17	3600204	Muffler stud bolt	36	3600134	Gasket kit
18	4800104	Spark plug	37	8100153	Engine oil 10W-30
19	3600132	Spark plug cap			